

Corrugated Horn Antenna  
15dBi Gain, 6.5-10.6GHz Frequency Range

## Corrugated Horn Antenna Data Sheet

**RM-CGHA610-15**

### Specifications

RM-CGHA610-15		
Parameters	Specification	Unit
Frequency Range	6.5-10.6	GHz
Gain	15 min	dBi
VSWR	<1.5	
Azimuth Beamwidth(3dB)	20 Typ.	Deg
Elevation Beamwidth(3dB)	20 Typ.	Deg
Front to Back Ratio	-35min	dB
Cross Polarization	-25min	dB
Side Lobe	-15min	dBc
Polarization	Linear Vertical	
Input Impedance	50	Ohm
Connector	N-Female	
Material	Al	
Finishing	Paint	
Size(L*W*H)	703*Ø158.8 (±5)	mm
Weight	4.760	kg
Operating Temp	-40~70	°C

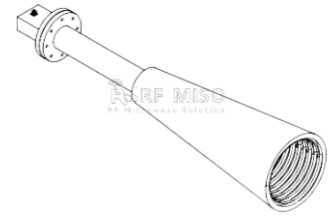

Corrugated Horn Antenna  
15dBi Gain, 6.5-10.6GHz Frequency Range

**Corrugated Horn Antenna Data Sheet**

**RM-CGHA610-15**

**Outline Drawing**

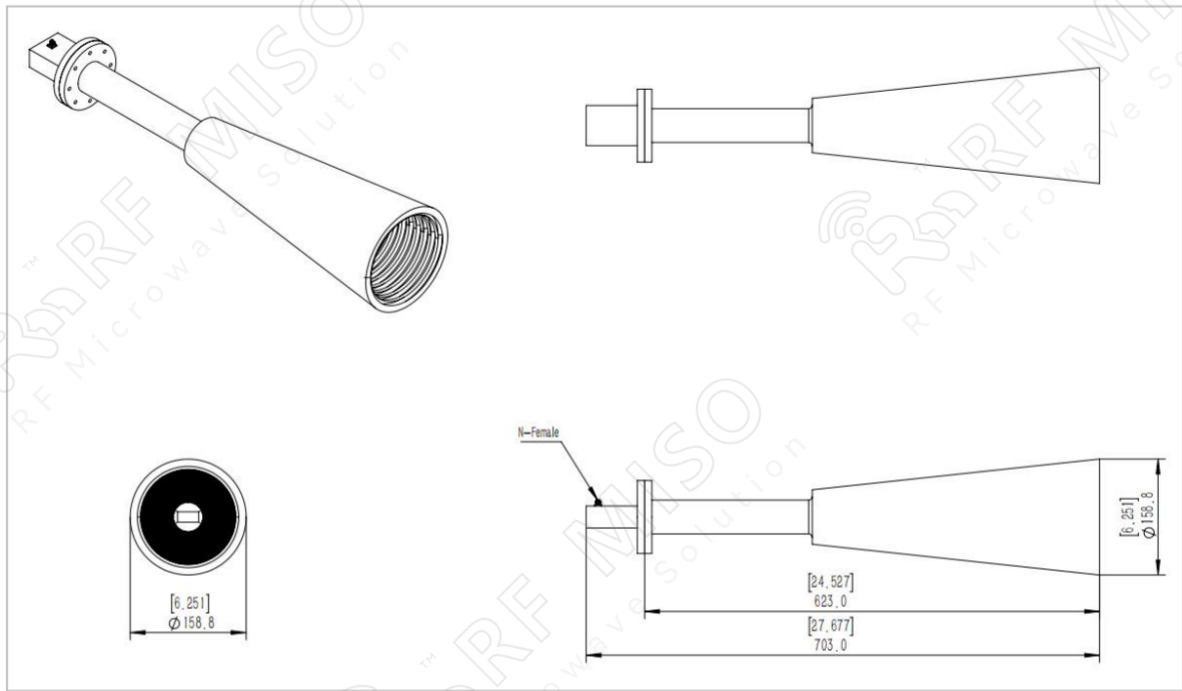

**Simulated Results**

VSWR

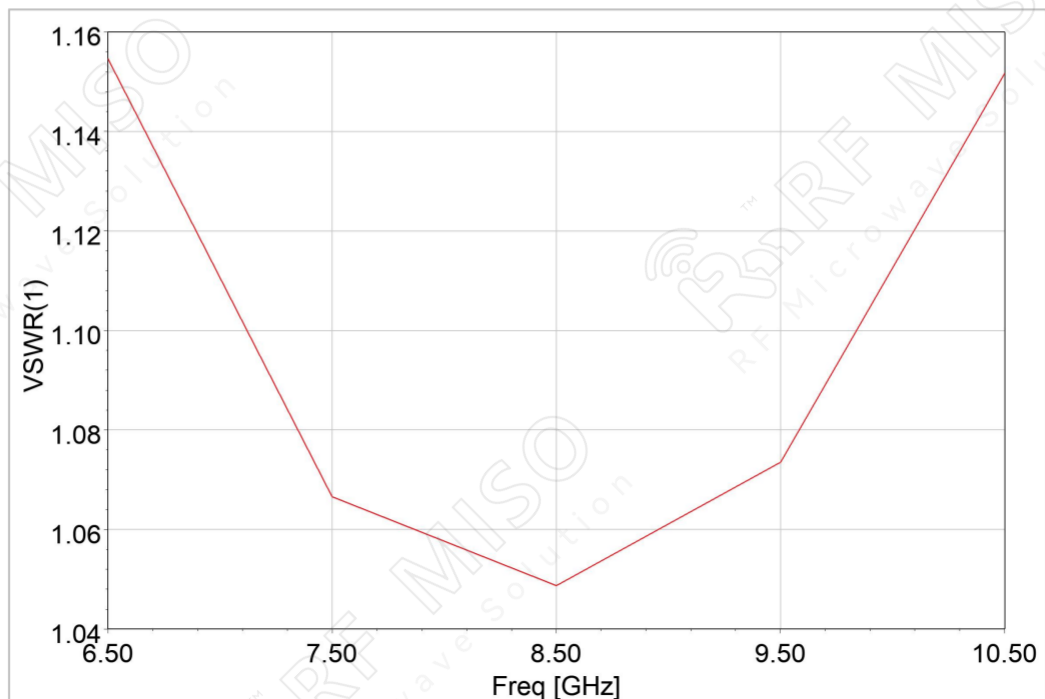

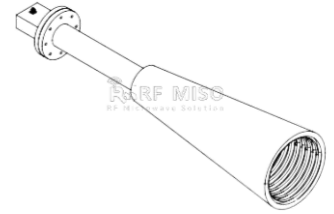

*Corrugated Horn Antenna*  
*15dBi Gain, 6.5-10.6GHz Frequency Range*

**Corrugated Horn Antenna Data Sheet**

**RM-CGHA610-15**

Gain Pattern

6.5GHz

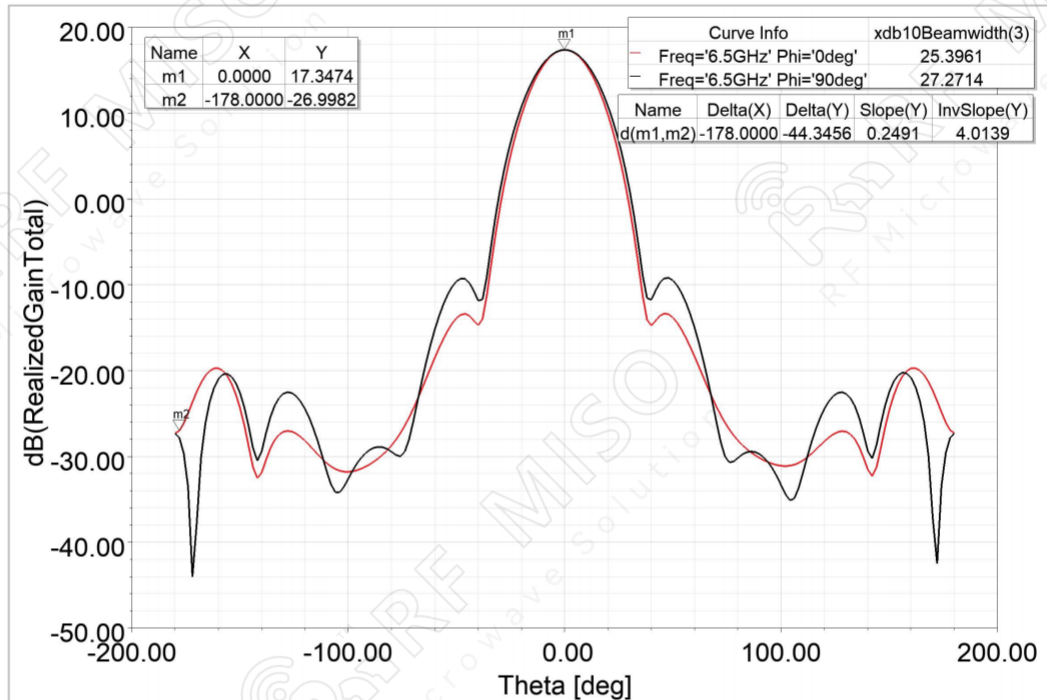

8.5GHz

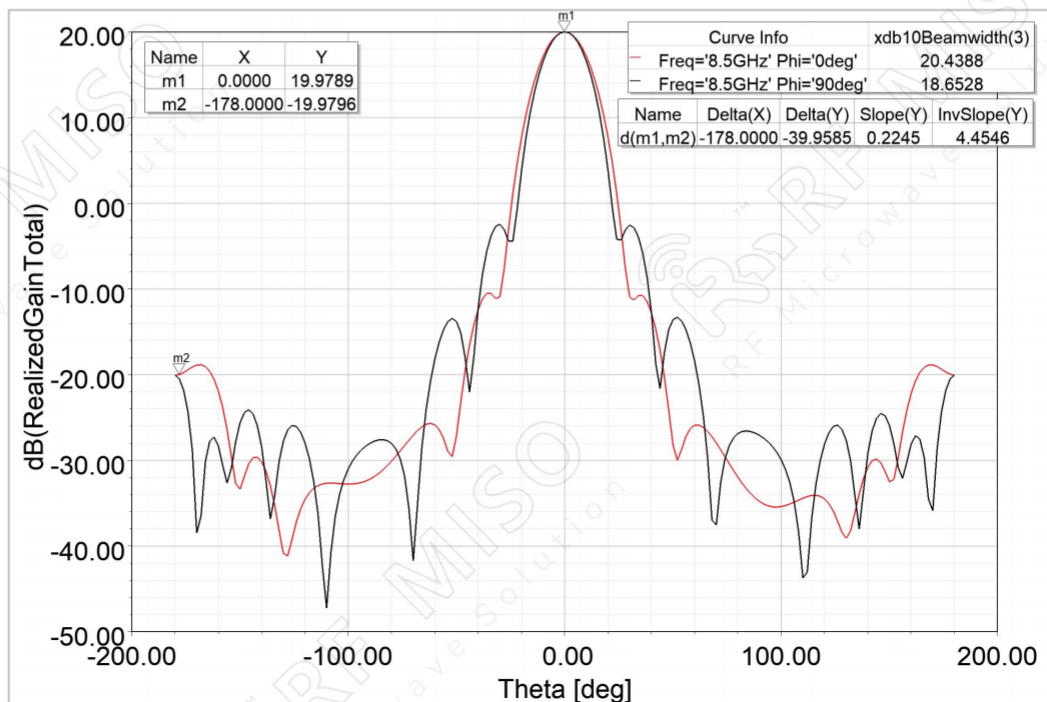

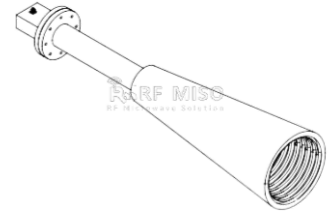

Corrugated Horn Antenna  
15dBi Gain, 6.5-10.6GHz Frequency Range

**Corrugated Horn Antenna Data Sheet**

**RM-CGHA610-15**

10.5GHz

