

*Dual Circular Polarized Horn Antenna
12dBi Typ. Gain, 18-40GHz Frequency Range*

Dual Circular Polarized Horn Antenna Data Sheet

RM-DCPHA1840-12

Features

- Coaxial Adapter for RF Inputs
- Strong Anti-interference
- High Transfer Rate
- Small Size

Descriptions

RF MISO's **Model RM-DCPHA1840-12** is a dual circular polarized horn antenna that operates from 18 to 40GHz, The antenna offers 12 dBi typical gain. The antenna VSWR below 2. The antenna RF ports are 2.92-female coaxial connector. The antenna can be widely used in EMI detection, orientation, reconnaissance, antenna gain and pattern measurement and other application fields.

Specifications

RM-DCPHA1840-12			
Parameters	Typical		Units
Frequency Range	18-40		GHz
Gain	12 Typ.		dBi
VSWR	≤2 Typ.		
Polarization	Dual-Circular-polarized		
AR	1.5 Typ.	3 max	dB
3dB Beam-width	27°-54°		dB
Port Isolation	15 Typ.		dB
Size (L*W*H)	46*40*55(±5)		mm
Weight	0.053		kg
Power Handling, CW	20		w
material	Al		
connector	2.92-Female		

Dual Circular Polarized Horn Antenna
12dBi Typ. Gain, 18-40GHz Frequency Range

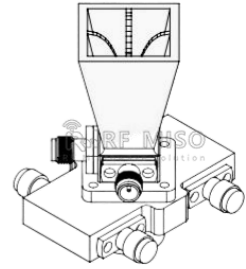

Dual Circular Polarized Horn Antenna Data Sheet

RM-DCPHA1840-12

Outline Drawing

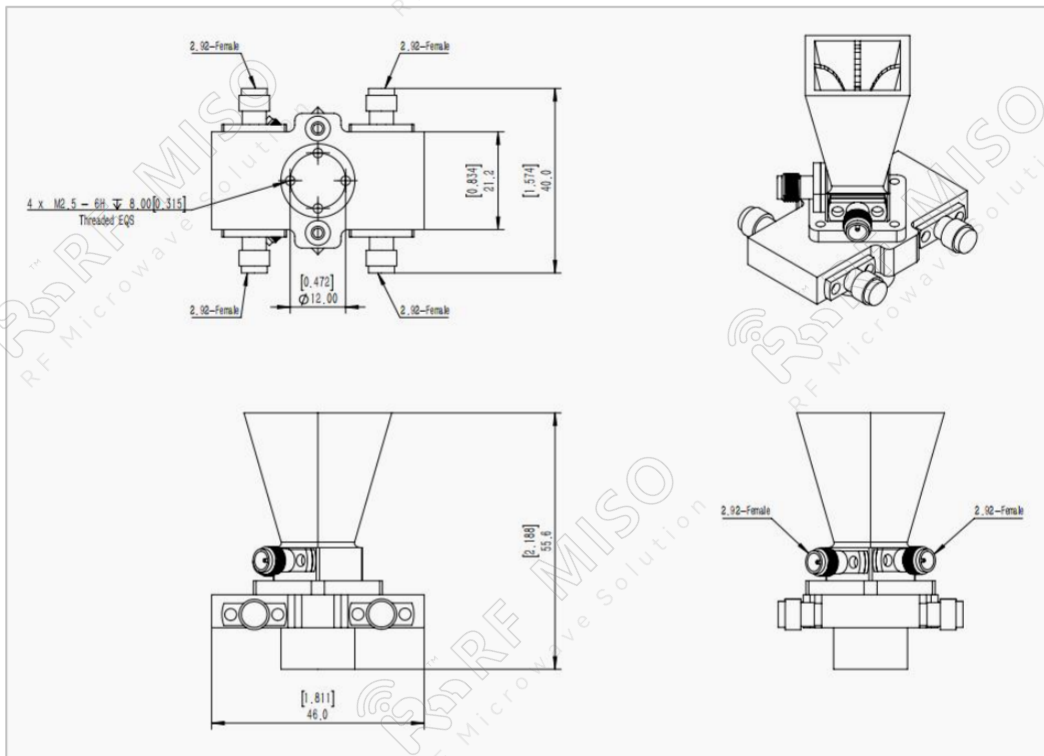

Simulation Results:

VSWR

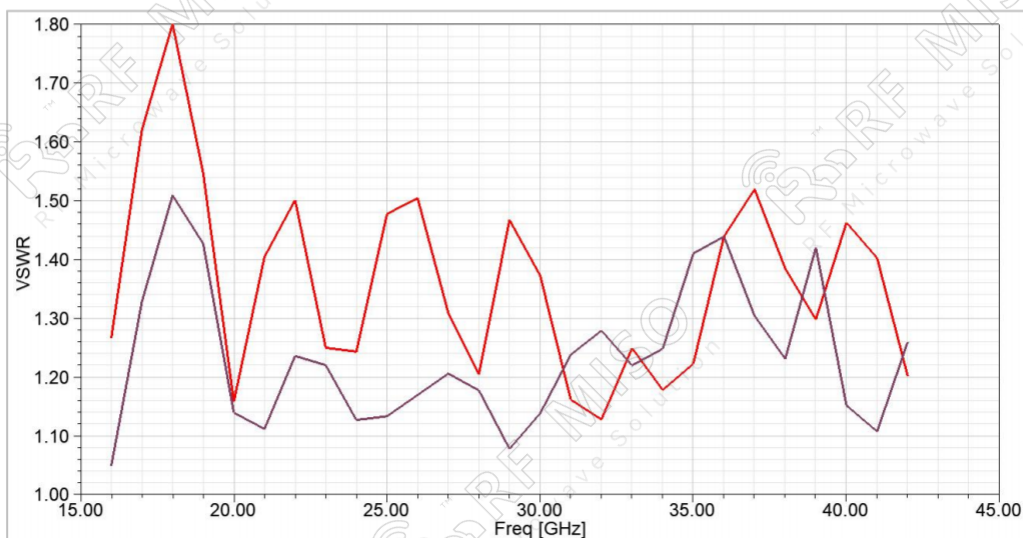

Dual Circular Polarized Horn Antenna
12dBi Typ. Gain, 18-40GHz Frequency Range

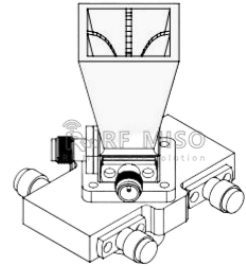

Dual Circular Polarized Horn Antenna Data Sheet

RM-DCPHA1840-12

Gain

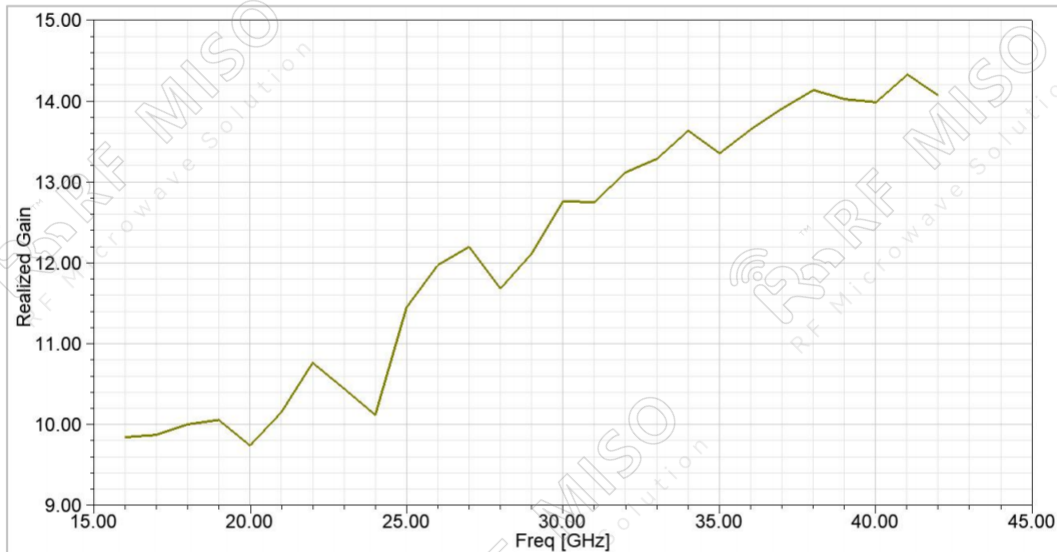

Axis Ratio

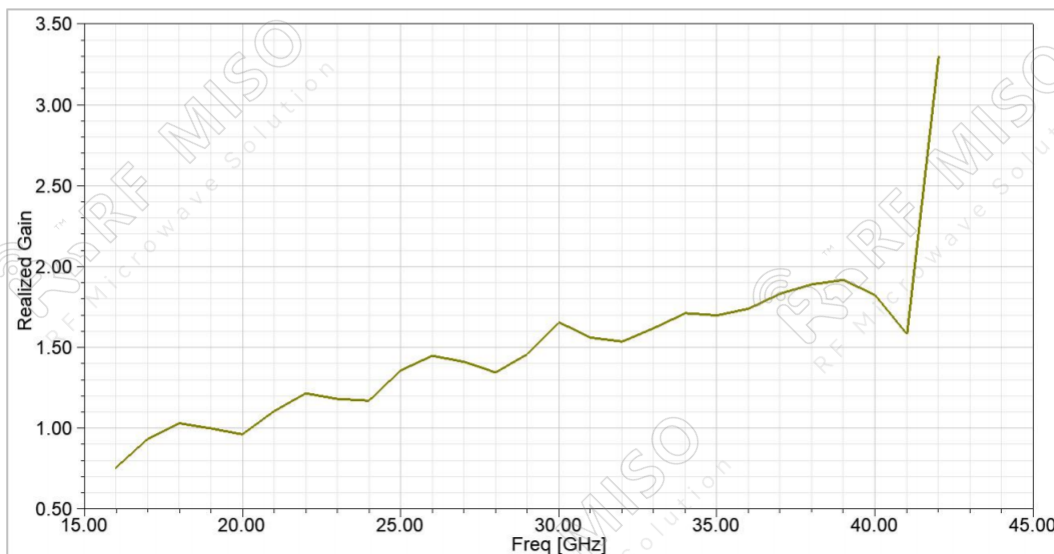

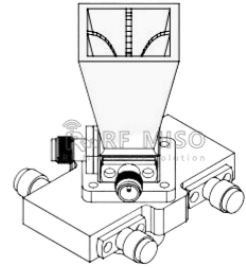

Dual Circular Polarized Horn Antenna
12dBi Typ. Gain, 18-40GHz Frequency Range

Dual Circular Polarized Horn Antenna Data Sheet

RM-DCPHA1840-12

Gain Pattern

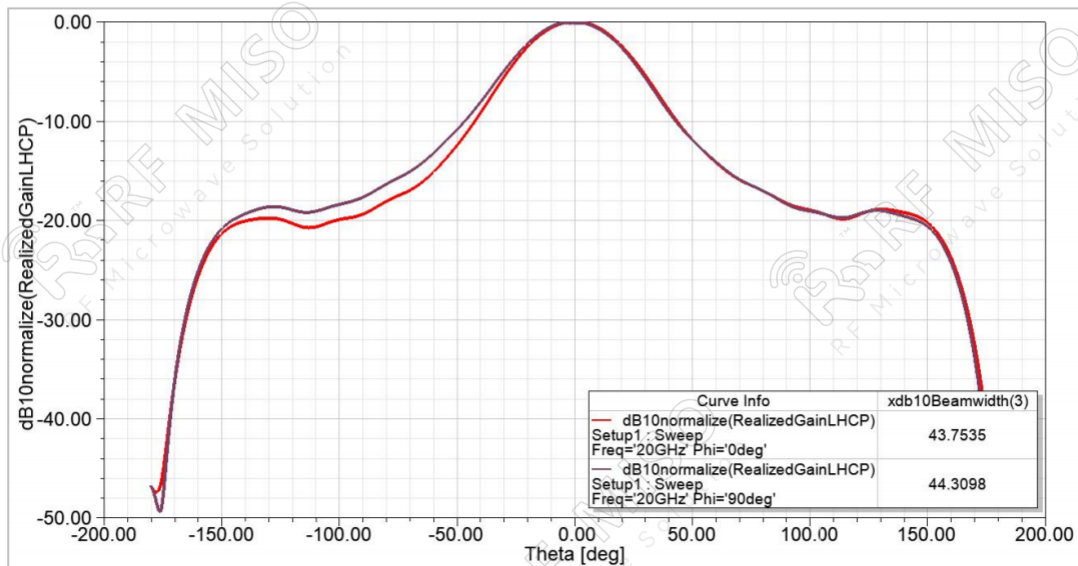
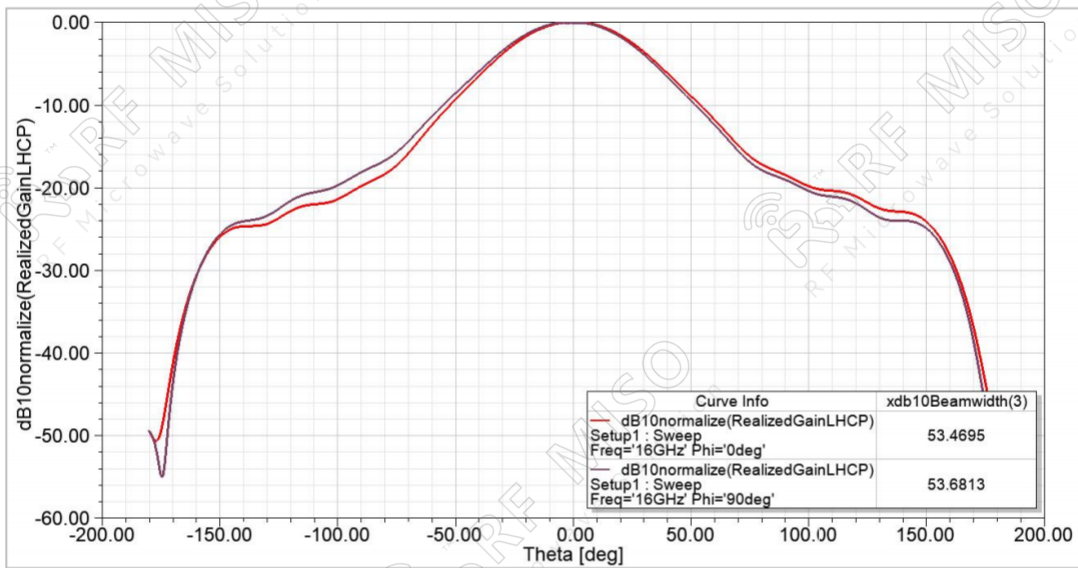

Dual Circular Polarized Horn Antenna
12dBi Typ. Gain, 18-40GHz Frequency Range

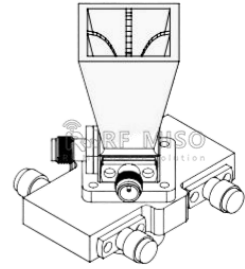

Dual Circular Polarized Horn Antenna Data Sheet

RM-DCPHA1840-12

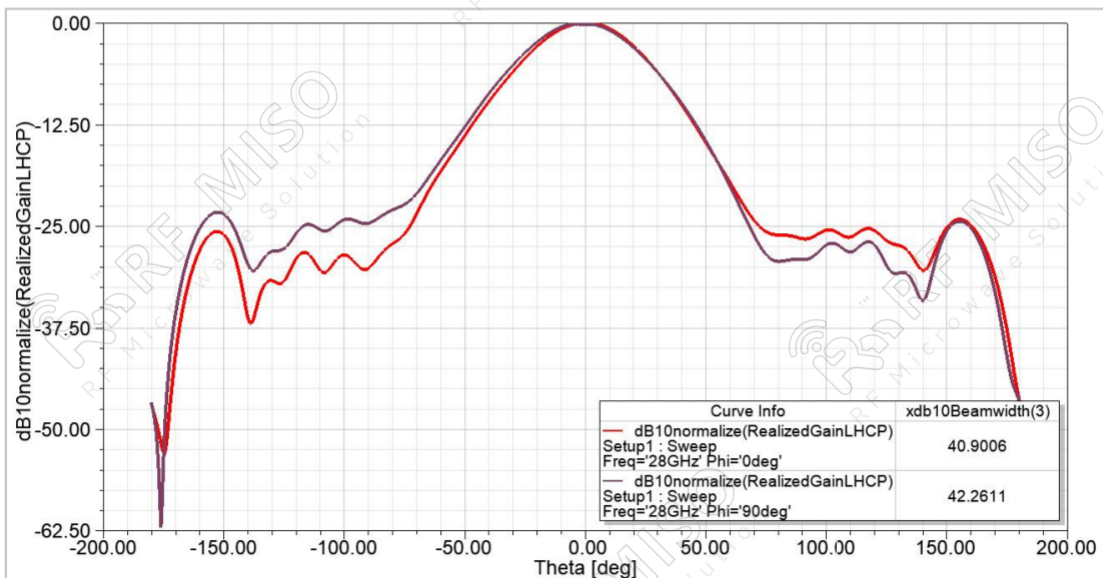
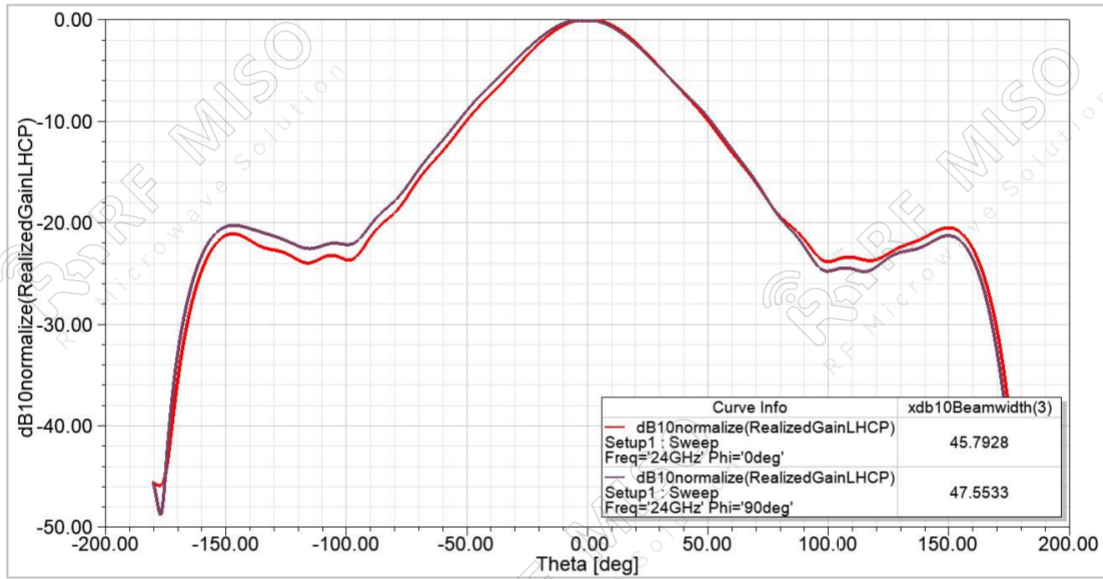

Dual Circular Polarized Horn Antenna
12dBi Typ. Gain, 18-40GHz Frequency Range

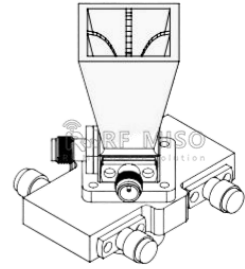

Dual Circular Polarized Horn Antenna Data Sheet

RM-DCPHA1840-12

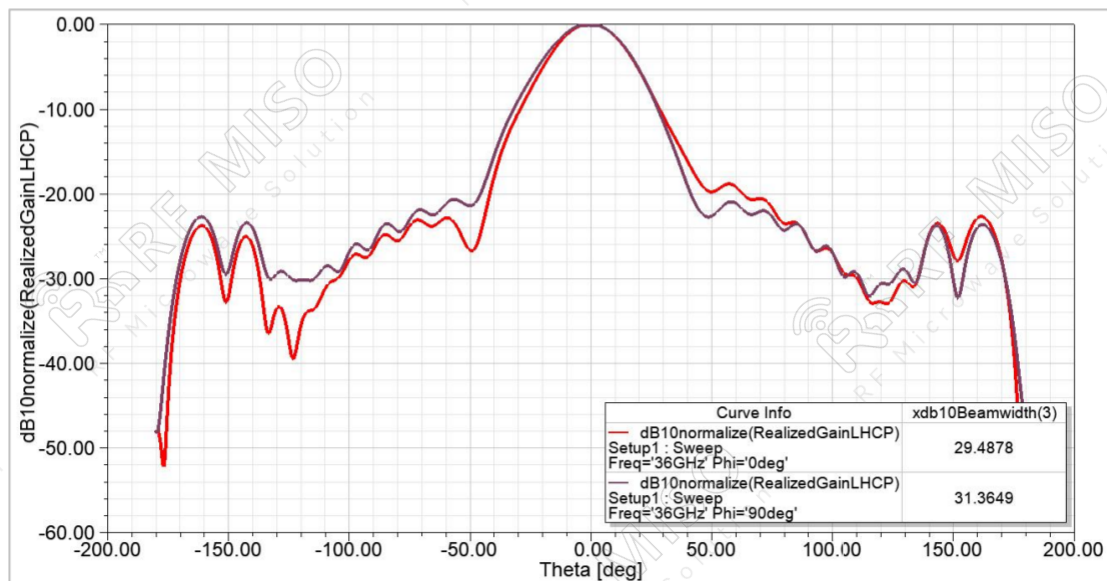
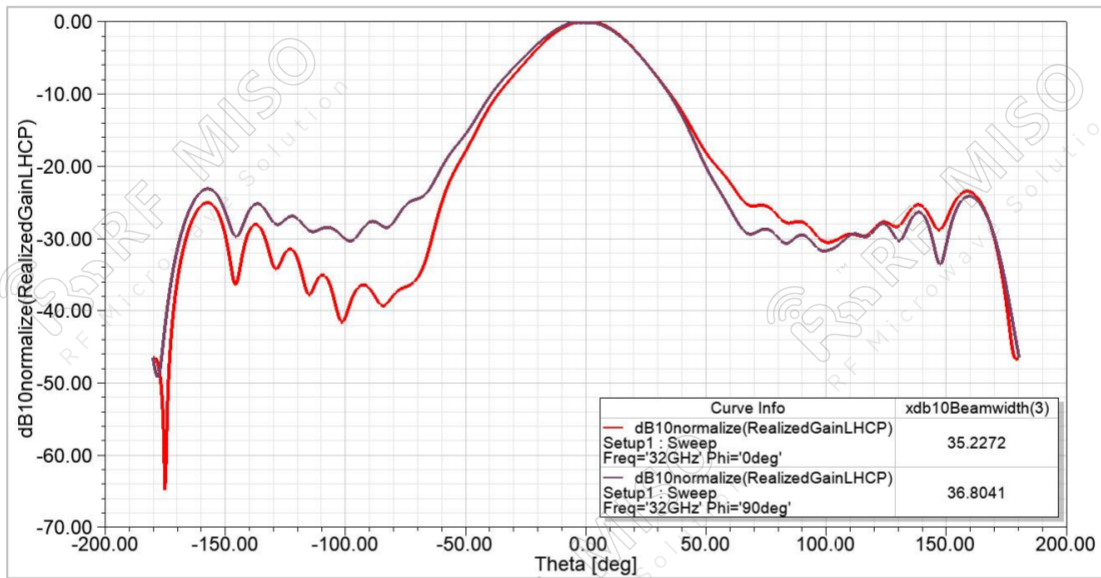

Dual Circular Polarized Horn Antenna
12dBi Typ. Gain, 18-40GHz Frequency Range

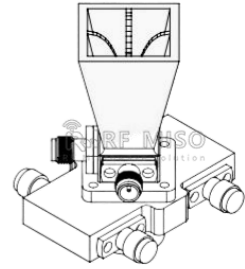

Dual Circular Polarized Horn Antenna Data Sheet

RM-DCPHA1840-12

