

Standard Gain Horn Antenna  
20dBi Typ. Gain, 3.30-4.90 GHz Frequency Range

## Standard Gain Horn Antenna Data Sheet

**RM-SGHA229-20**

### Features

- Wave-guide and Connector Interface
- Low Side-lobe
- Linear Polarization
- High Return Loss

### Descriptions

RF MISO's **Model RM-SGHA229-20** is a linear polarized standard gain horn antenna that operates from 3.30 to 4.90 GHz. The antenna offers a typical gain of 20 dBi and low VSWR 1.3:1. The antenna has a typical 3dB beamwidth of 17.3 degrees on the E plane and 17.5 degrees on H plane. This antenna has flange input and coaxial input for customers to rotate. Antenna mounting brackets include ordinary L-type mounting bracket and rotating L-type bracket<sup>①</sup>

### Specifications

Parameters	Specification		Unit
Frequency Range	3.30-4.90		GHz
Wave-guide	WR229		
Gain	20 Typ.		dBi
VSWR	1.3 Typ.		
Polarization	Linear		
3 dB Beamwidth, E-Plane	17.3° Typ.		
3 dB Beamwidth, H-Plane	17.5° Typ.		
Interface	FDP40(F Type)	N-KFD(C Type)	
Material	Al		
Finishing	Paint		
Size,C Type (L*W*H)	673.5*290.6*217.1 (±5)		mm
Weight	2.892(F Type)	3.187(C Type)	kg
C Type Average Power	150		w
C Type Peak Power	3000		w
Operating Temperature	-40° ~+85°		° C

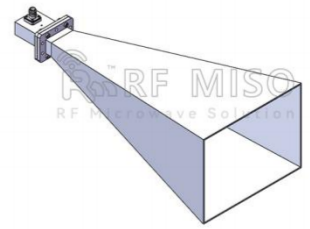

Standard Gain Horn Antenna  
20dBi Typ. Gain, 3.30-4.90 GHz Frequency Range

**Standard Gain Horn Antenna Data Sheet**

**RM-SGHA229-20**

**F-Type Mechanical Drawing (P/N: RM-SGHA229-20F)**

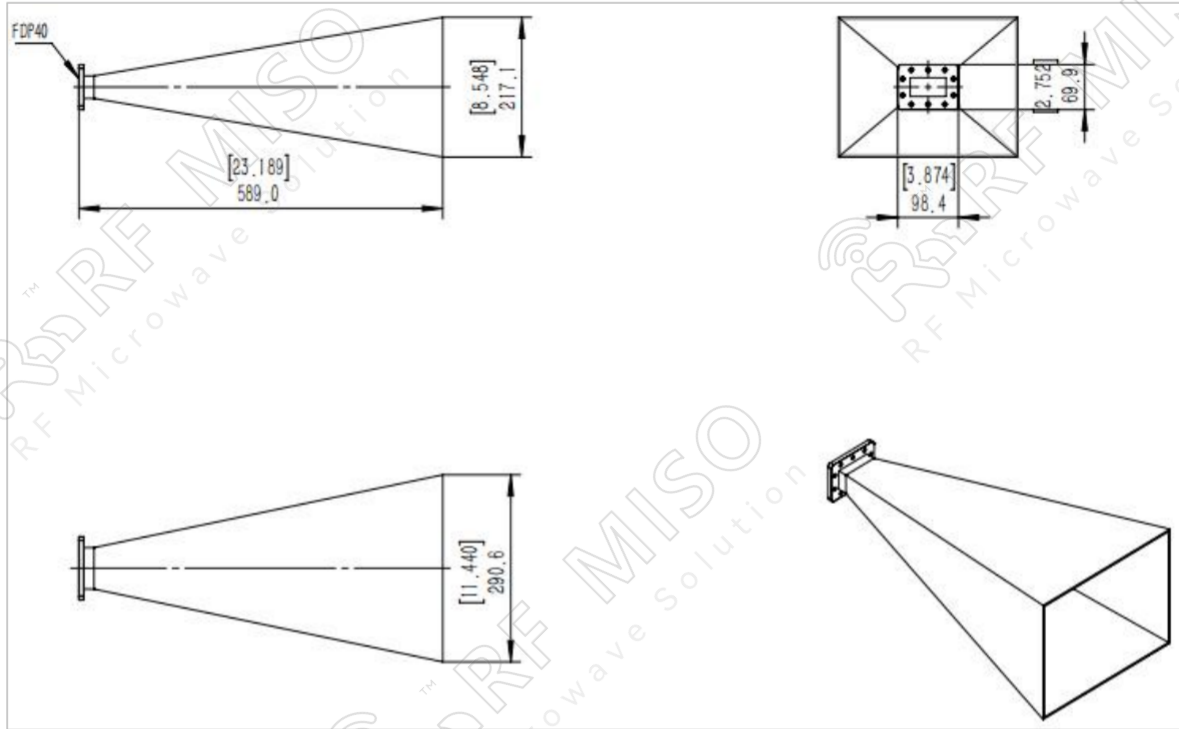

**C-Type Mechanical Drawing (P/N: RM-SGHA229-20C)**

SMA connector is available, please contact RF Miso.

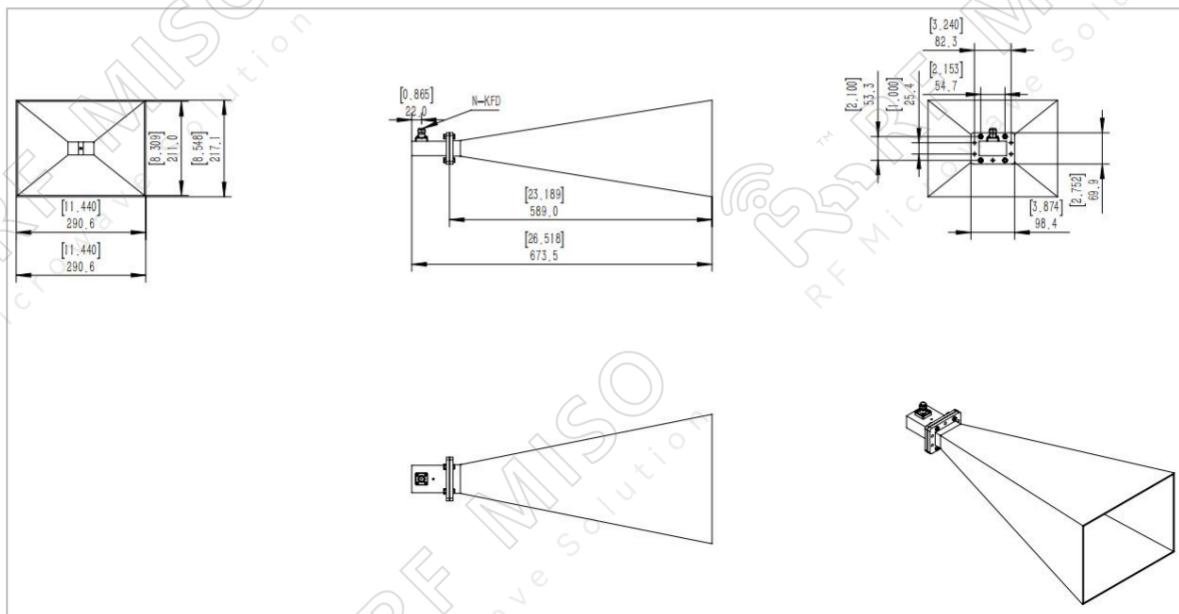

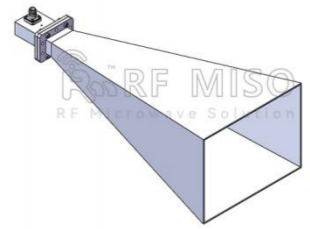

Standard Gain Horn Antenna  
20dBi Typ. Gain, 3.30-4.90 GHz Frequency Range

**Standard Gain Horn Antenna Data Sheet**

**RM-SGHA229-20**

**D-Mechanical Drawing with Ordinary L-type Mounting Bracket (P/N: RM-SGHA229-20CL)**

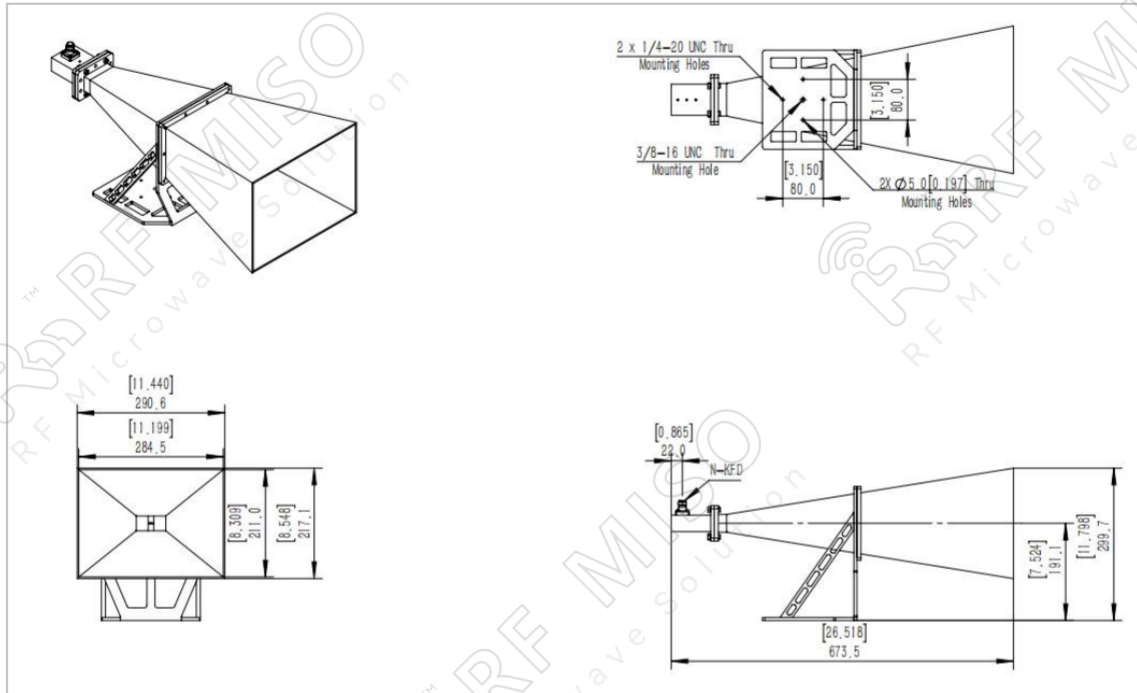

**VSWR**

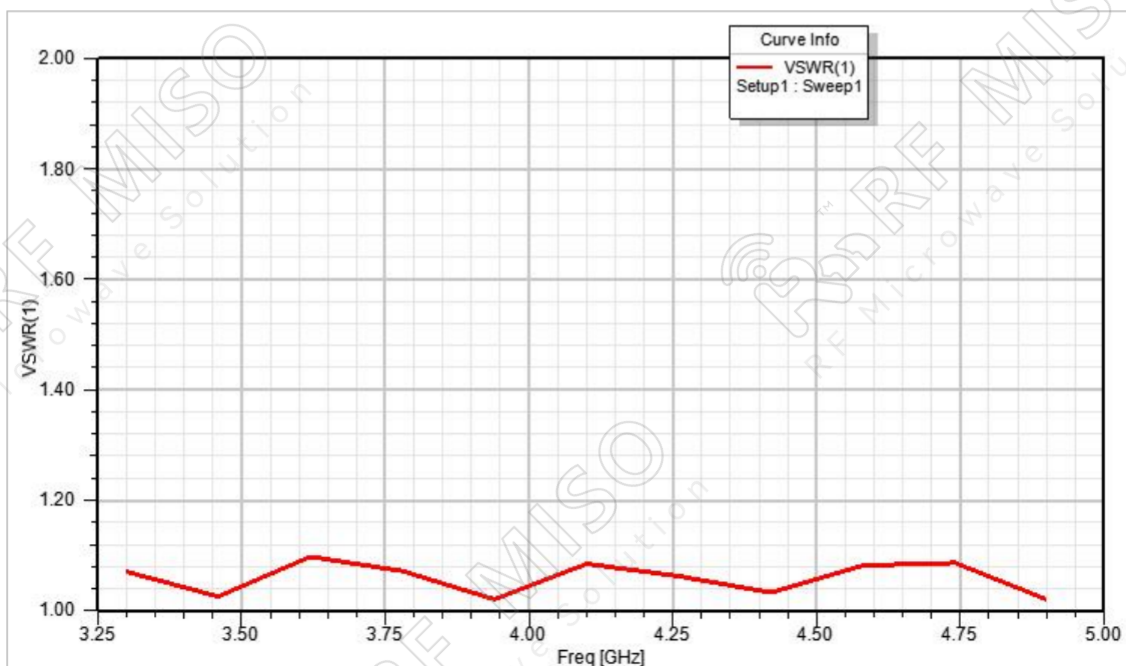

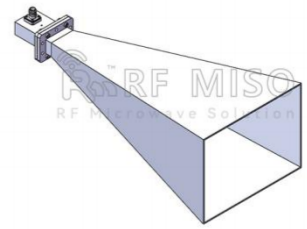

Standard Gain Horn Antenna  
20dBi Typ. Gain, 3.30-4.90 GHz Frequency Range

**Standard Gain Horn Antenna Data Sheet**

**RM-SGHA229-20**

Gain

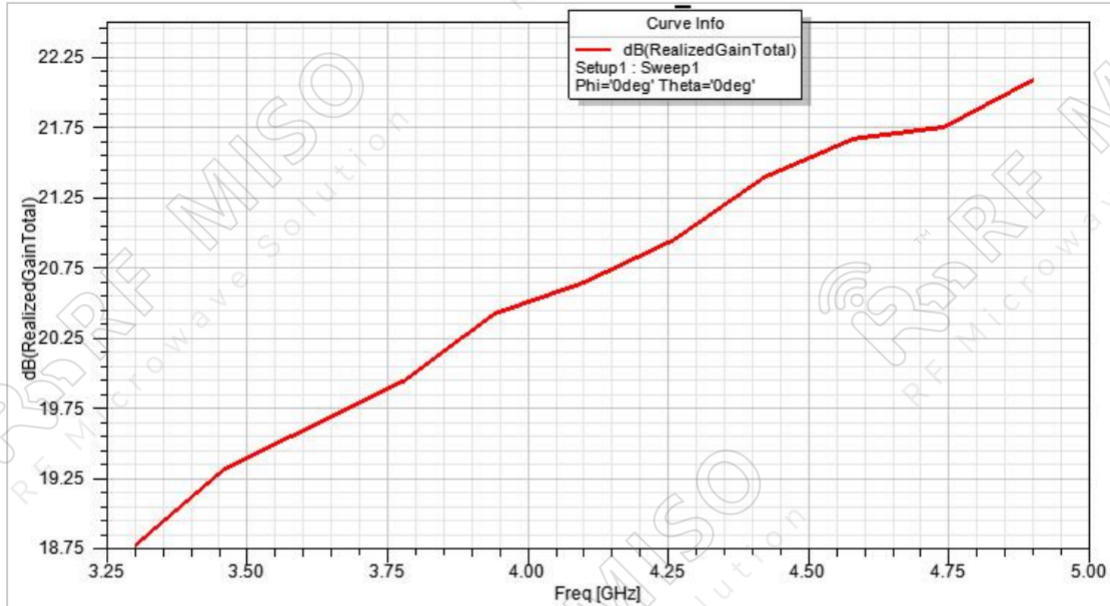

Gain Pattern E-plane

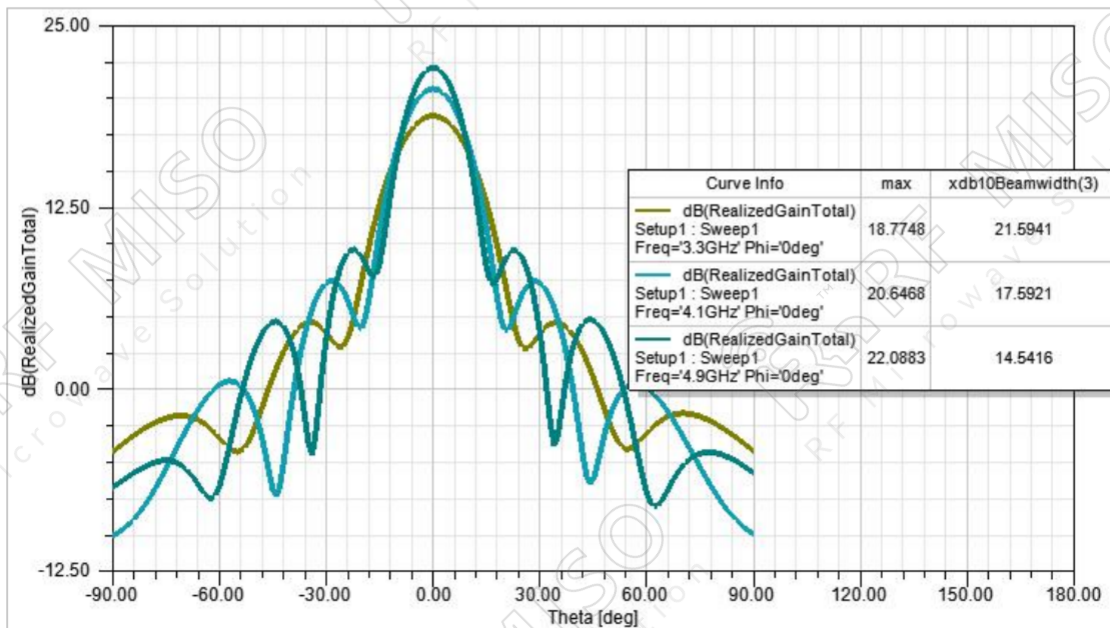



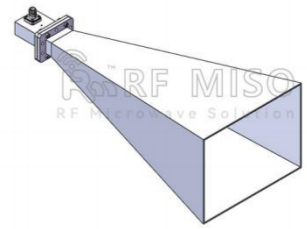

Standard Gain Horn Antenna  
20dBi Typ. Gain, 3.30-4.90 GHz Frequency Range

**Standard Gain Horn Antenna Data Sheet**

**RM-SGHA229-20**

**Gain Pattern H-plane**

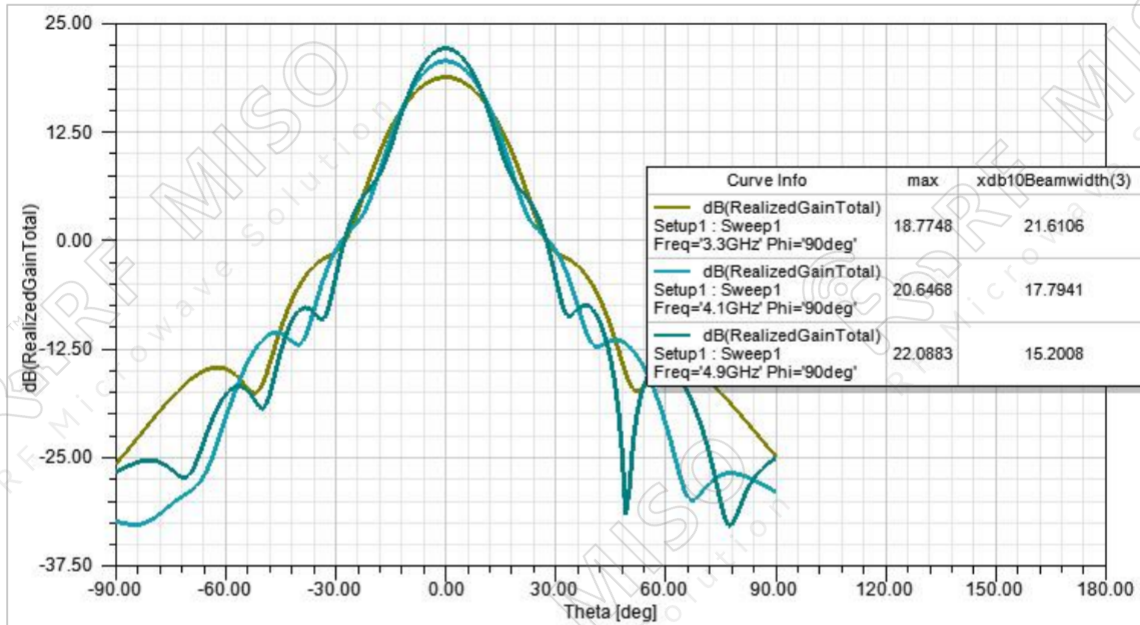

① **Rotating L-type bracket:** The rotating bracket is used for antenna polarization adjustment, and the tooling integrated with the bracket can precisely adjust the polarization directions of 0° , 45° , and 90° to ensure the accuracy and consistency of the calibration results.

Note:

- If the data presented is simulated. Actual data may vary unit to unit, slightly.
- Any foreign objects in the wave-guide will cause performance degradation and possible device damage.
- We can customize antennas according to your specific needs.