



Standard Gain Horn Antenna  
15dBi Typ. Gain, 26.5-40 GHz Frequency Range

## Standard Gain Horn Antenna Data Sheet

**RM-SGHA28-15**

### Features

- Wave-guide and Connector Interface
- Low Side-lobe
- Linear Polarization
- High Return Loss

### Descriptions

RF MISO's **Model RM-SGHA28-15** is a linear polarized standard gain horn antenna that operates from 26.5 to 40 GHz. The antenna offers a typical gain of 15 dBi and low VSWR 1.3:1. The antenna has a typical 3dB beamwidth of 32 degrees on the E plane and 31 degrees on H plane. This antenna has flange input and coaxial input for customers to rotate. Antenna mounting brackets include ordinary L-type mounting bracket and rotating L-type bracket①

### Specifications

Parameters	Specification		Unit
Frequency Range	26.5-40		GHz
Wave-guide	WR28		
Gain	15 Typ.		dBi
VSWR	1.3 Typ.		
Polarization	Linear		
3 dB Beamwidth, E-Plane	32° Typ.		
3 dB Beamwidth, H-Plane	31° Typ.		
Interface	FBP320(F Type)	2.92-Female(C Type)	
Material	Al		
Finishing	Paint		
C Type Size (L*W*H)	54*19.1*24.4 (±5)		mm
Weight	0.008 (F Type)	0.017(C Type)	kg
C Type Average Power	20		W
C Type Peak Power	40		W
Operating Temperature	-40° ~+85°		° C



Standard Gain Horn Antenna  
15dBi Typ. Gain, 26.5-40 GHz Frequency Range

**Standard Gain Horn Antenna Data Sheet**

**RM-SGHA28-15**

**F-Type Mechanical Drawing (P/N: RM-SGHA28-15F)**

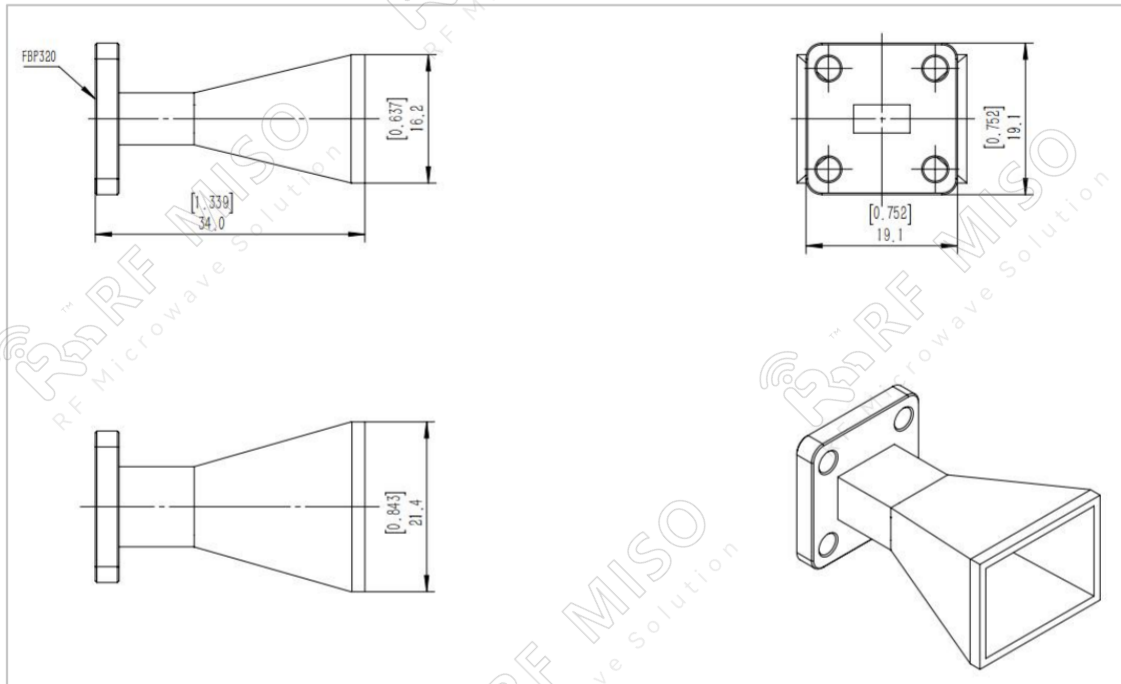

**C-Type Mechanical Drawing (P/N: RM-SGHA28-15C)**

2.4mm-type connector is available, please contact RF Miso.

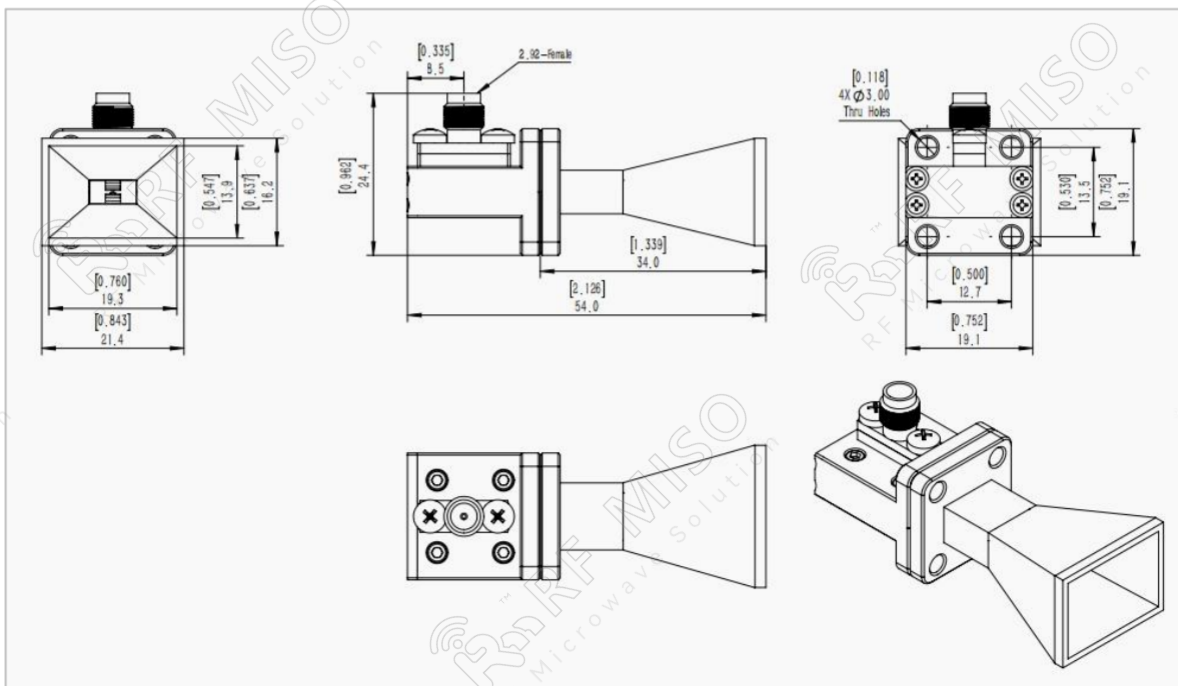



Standard Gain Horn Antenna  
15dBi Typ. Gain, 26.5-40 GHz Frequency Range

**Standard Gain Horn Antenna Data Sheet**

**RM-SGHA28-15**

**Mechanical Drawing with Ordinary L-type Mounting Bracket (P/N: RM-SGHA28-15CL)**

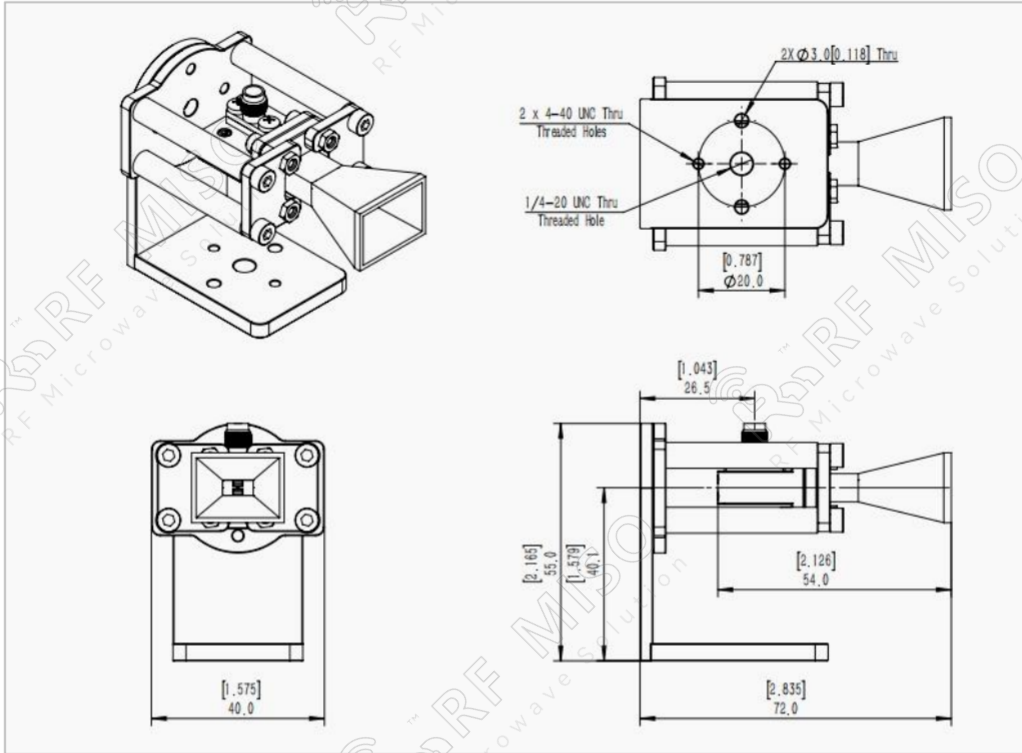

**Mechanical Drawing with Rotating L-type Mounting Bracket (P/N: RM-SGHA28-15CR)**

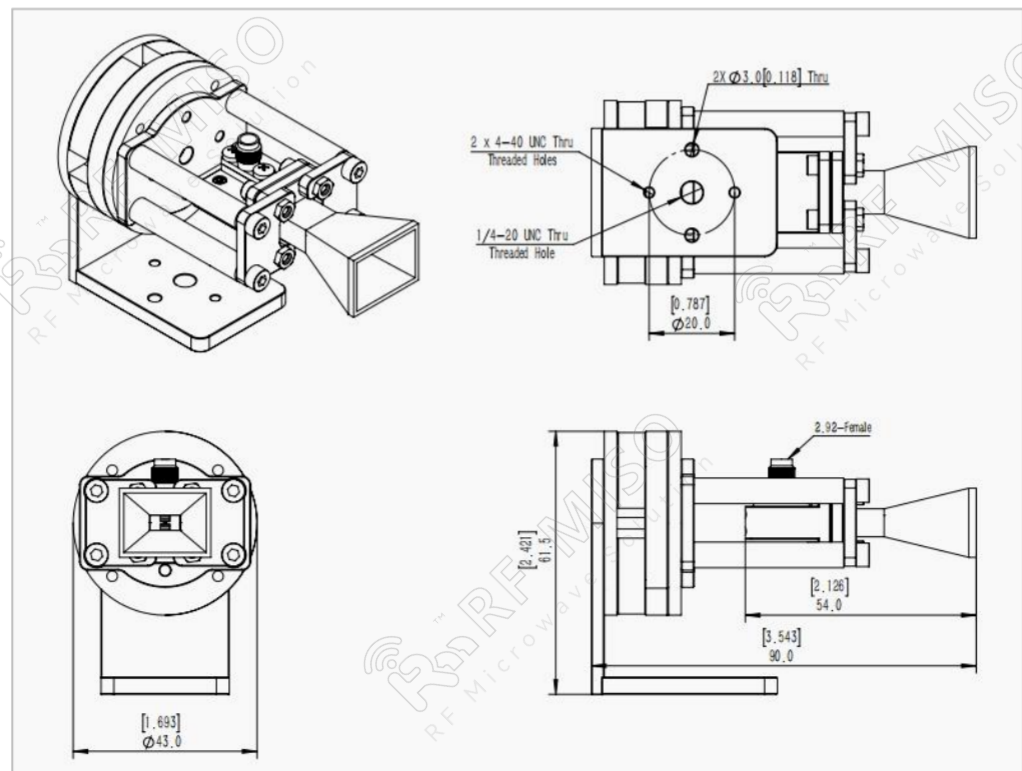



Standard Gain Horn Antenna  
15dBi Typ. Gain, 26.5-40 GHz Frequency Range

**Standard Gain Horn Antenna Data Sheet**

**RM-SGHA28-15**

**Mechanical Drawing with Ordinary I-type Mounting Bracket (P/N: RM-SGHA28-15CI)**

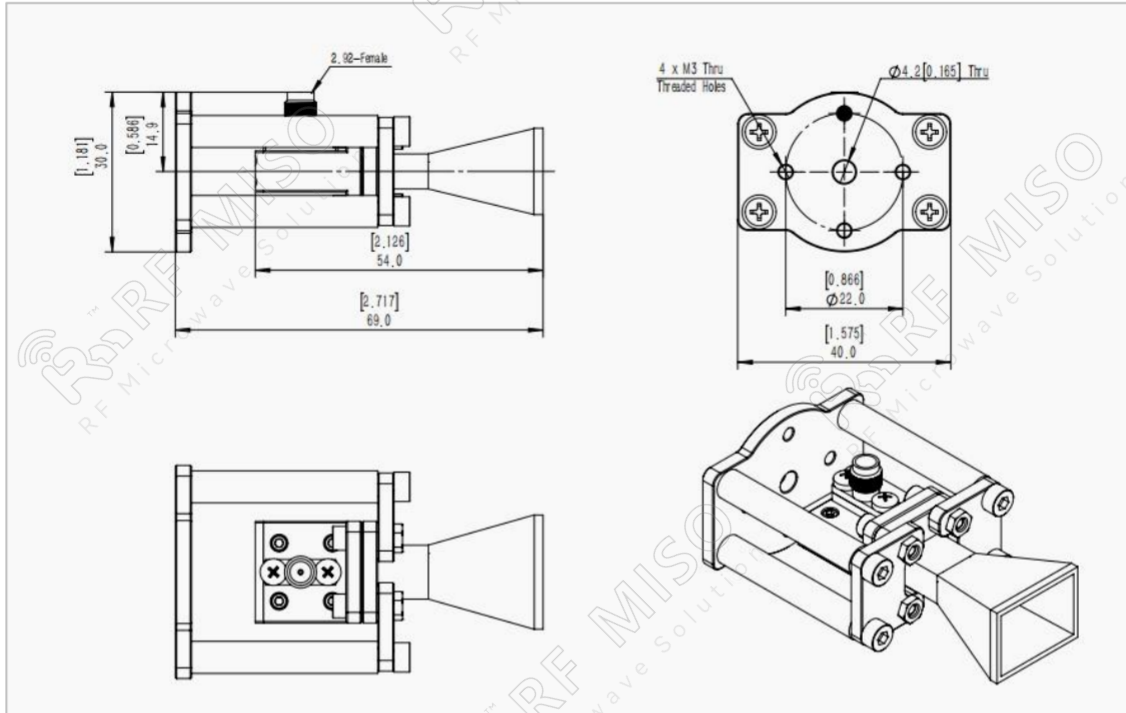

**VSWR**

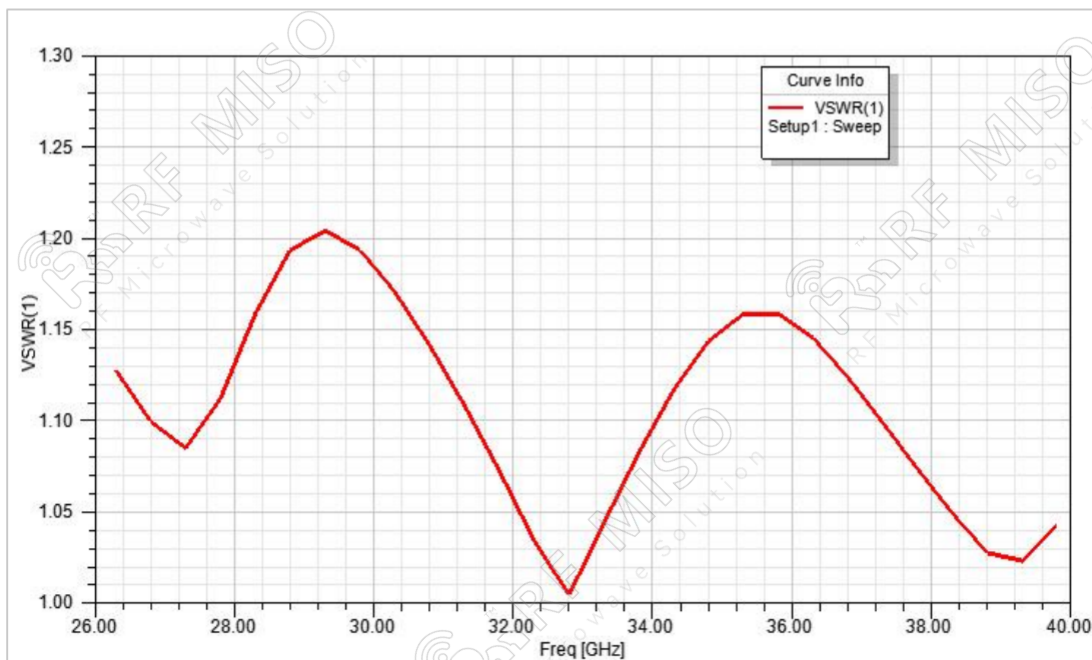





Standard Gain Horn Antenna  
15dBi Typ. Gain, 26.5-40 GHz Frequency Range

**Standard Gain Horn Antenna Data Sheet**

**RM-SGHA28-15**

**Gain**

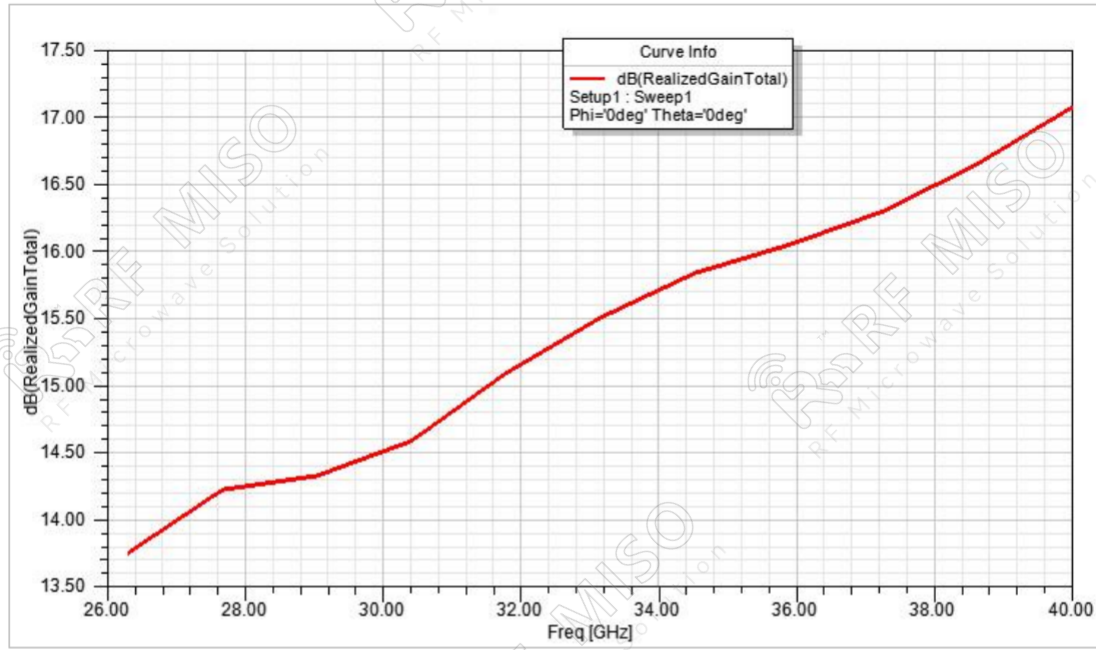

**Gain Pattern E-plane**

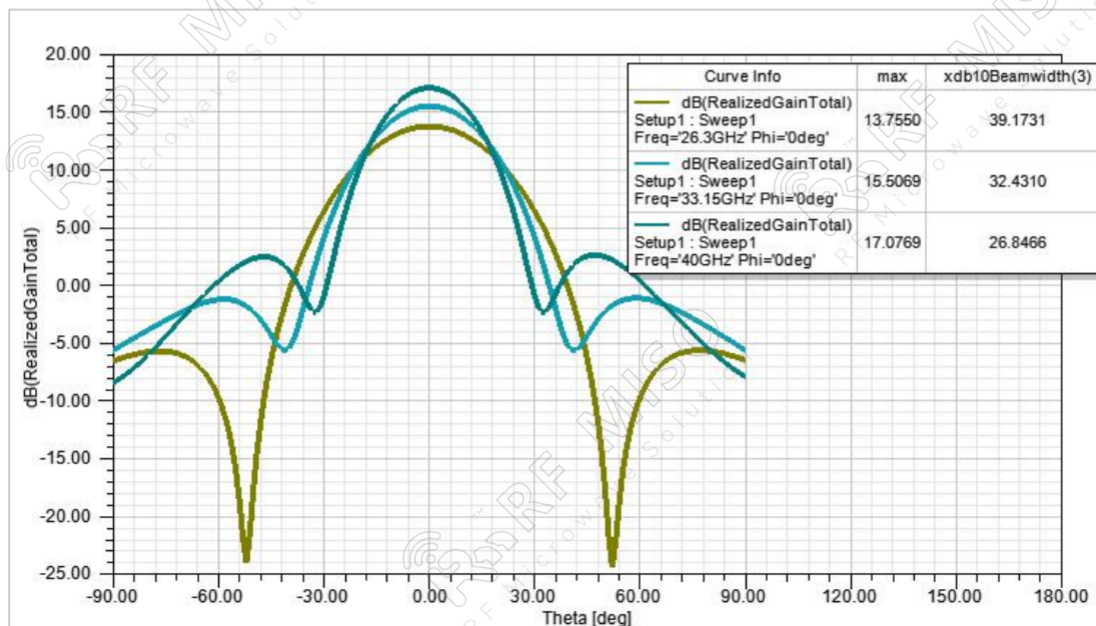



Standard Gain Horn Antenna  
15dBi Typ. Gain, 26.5-40 GHz Frequency Range

**Standard Gain Horn Antenna Data Sheet**

**RM-SGHA28-15**

**Gain Pattern H-plane**

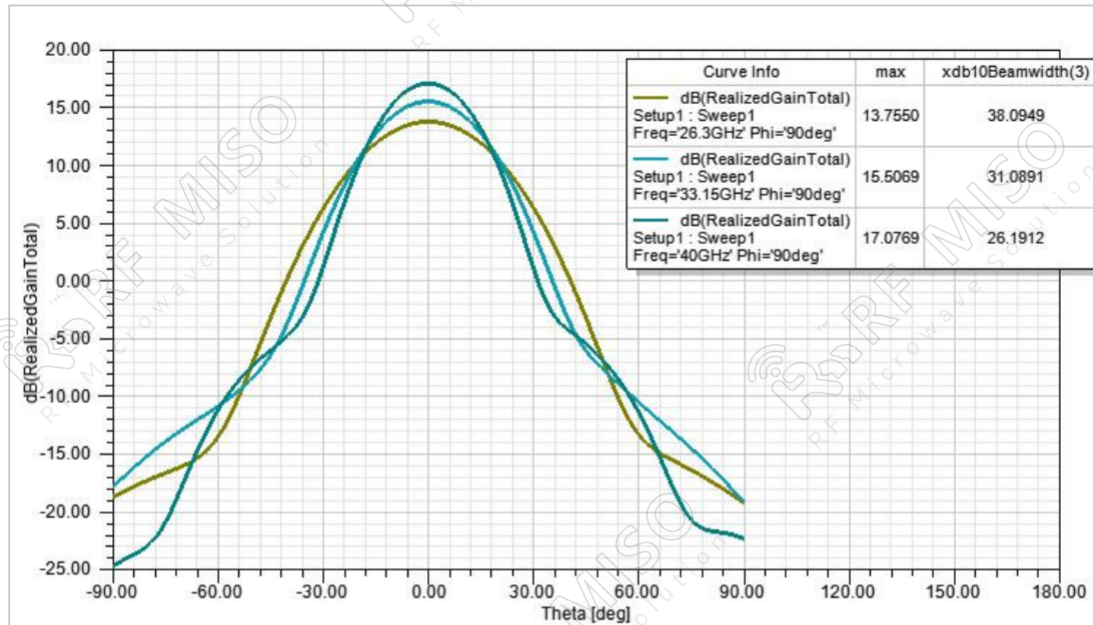

① **Rotating L-type bracket:** The rotating bracket is used for antenna polarization adjustment, and the tooling integrated with the bracket can precisely adjust the polarization directions of 0°, 45°, and 90° to ensure the accuracy and consistency of the calibration results

Note:

- If the data presented is simulated. Actual data may vary unit to unit, slightly.
- Any foreign objects in the wave-guide will cause performance degradation and possible device damage.
- We can customize antennas according to your specific needs.