

Standard Gain Horn Antenna
10dBi Typ. Gain, 1.70-2.60 GHz Frequency Range

Standard Gain Horn Antenna Data Sheet

RM-SGHA430-10

Features

- Wave-guide and Connector Interface
- Low Side-lobe
- Linear Polarization
- High Return Loss

Descriptions

RF MISO's **Model RM-SGHA430-10** is a linear polarized standard gain horn antenna that operates from 1.70 to 2.60 GHz. The antenna offers a typical gain of 10 dBi and low VSWR 1.3:1. The antenna has a typical 3dB beamwidth of 51.6 degrees on the E plane and 52.1 degrees on H plane. This antenna has flange input and coaxial input for customers to rotate. Antenna mounting brackets include ordinary L-type mounting bracket and rotating L-type bracket^①

Specifications

Parameters	Specification		Unit
Frequency Range	1.70-2.60		GHz
Wave-guide	WR430		
Gain	10 Typ.		dBi
VSWR	1.3 Typ.		
Polarization	Linear		
3 dB Beamwidth, E-Plane	51.6° Typ.		
3 dB Beamwidth, H-Plane	52.1° Typ.		
Interface	FDP22(F Type)	N-KFD(C Type)	
Material	Al		
Finishing	Paint		
Size,C Type (L*W*H)	351*170.1*137.4 (±5)		mm
Weight	0.832(F Type)	1.844(C Type)	kg
C Type Average Power	150		w
C Type Peak Power	3000		w
Operating Temperature	-40° ~+85°		° C

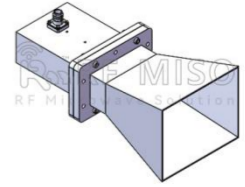

Standard Gain Horn Antenna
10dBi Typ. Gain, 1.70-2.60 GHz Frequency Range

Standard Gain Horn Antenna Data Sheet

RM-SGHA430-10

F-Type Mechanical Drawing (P/N: RM-SGHA430-10F)

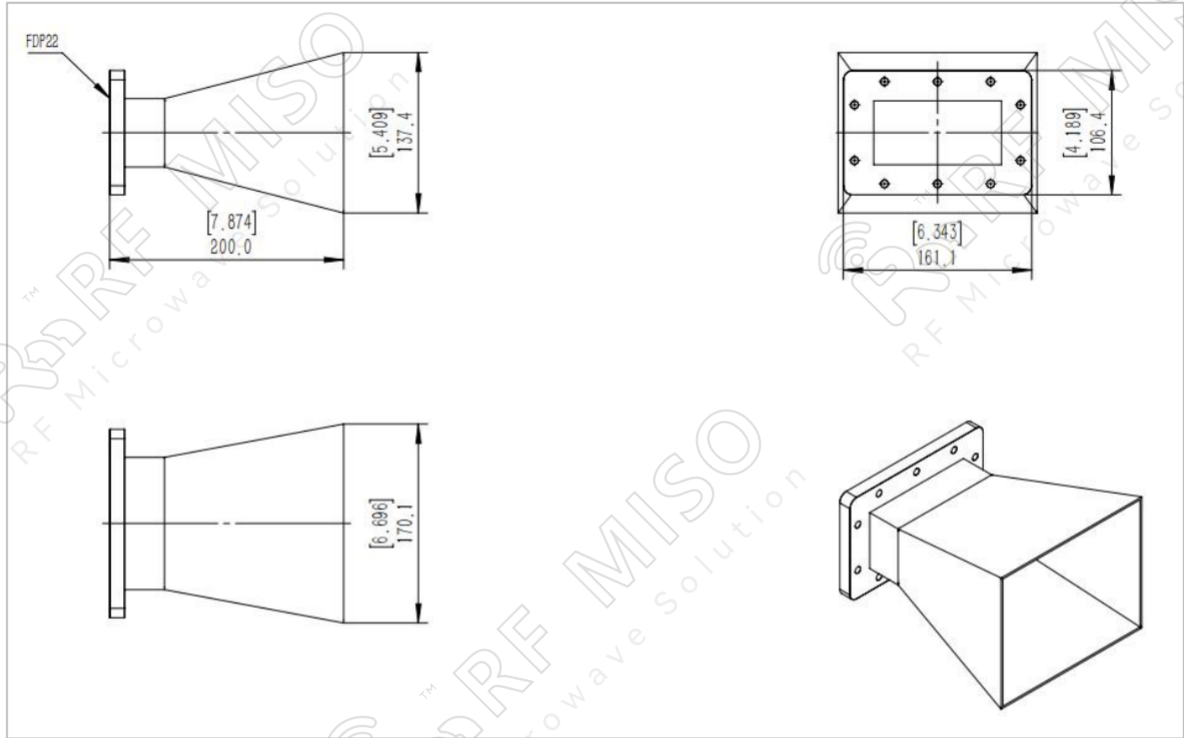

C-Type Mechanical Drawing (P/N: RM-SGHA430-10C)

SMA connector is available, please contact RF Miso.

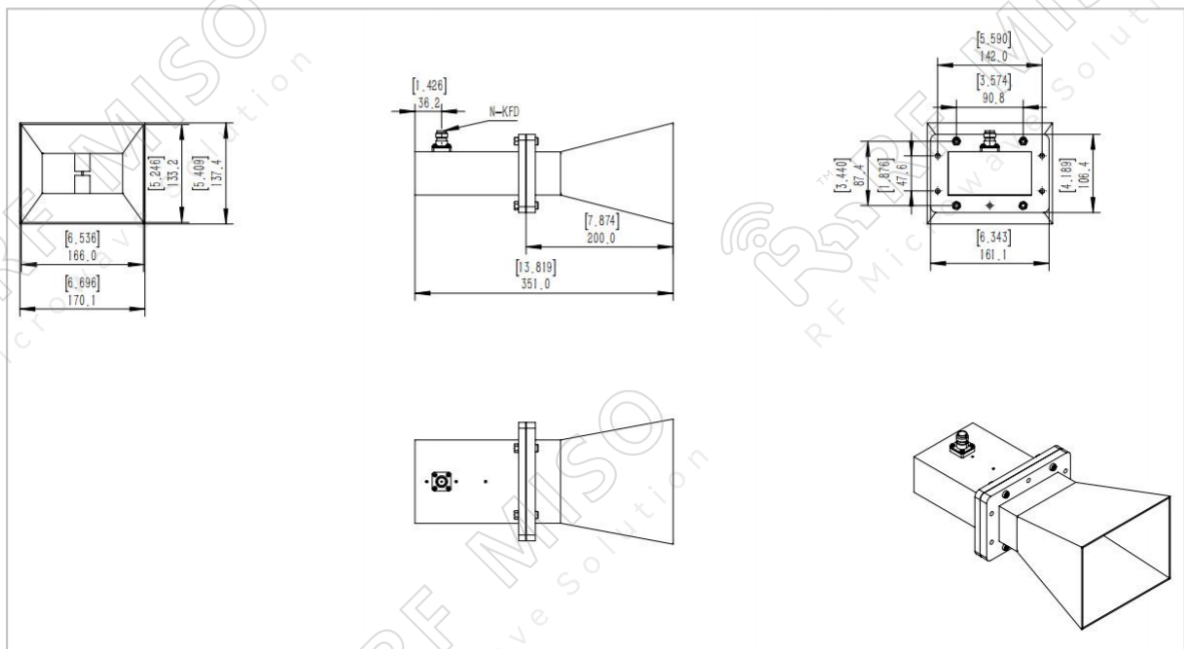

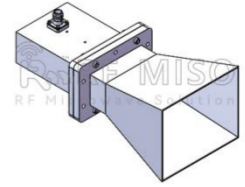

Standard Gain Horn Antenna
10dBi Typ. Gain, 1.70-2.60 GHz Frequency Range

Standard Gain Horn Antenna Data Sheet

RM-SGHA430-10

Mechanical Drawing with Ordinary L-type Mounting Bracket (P/N: RM-SGHA430-10CL)

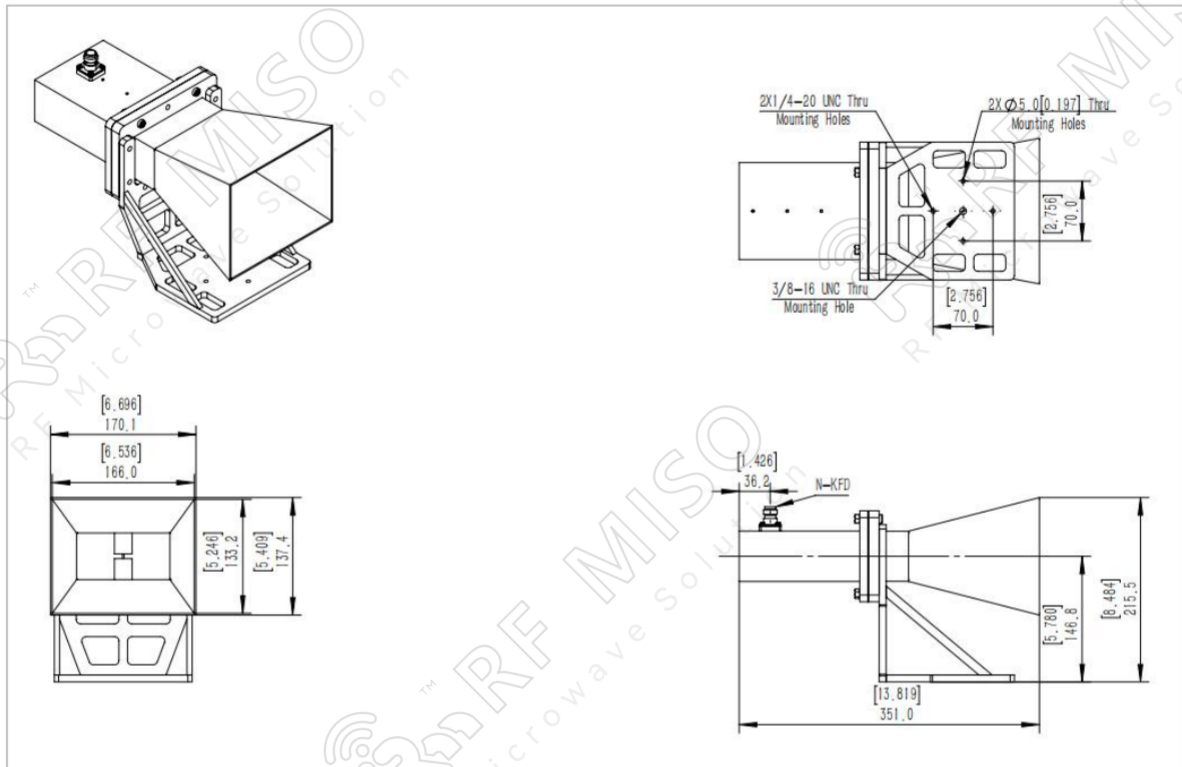

VSWR

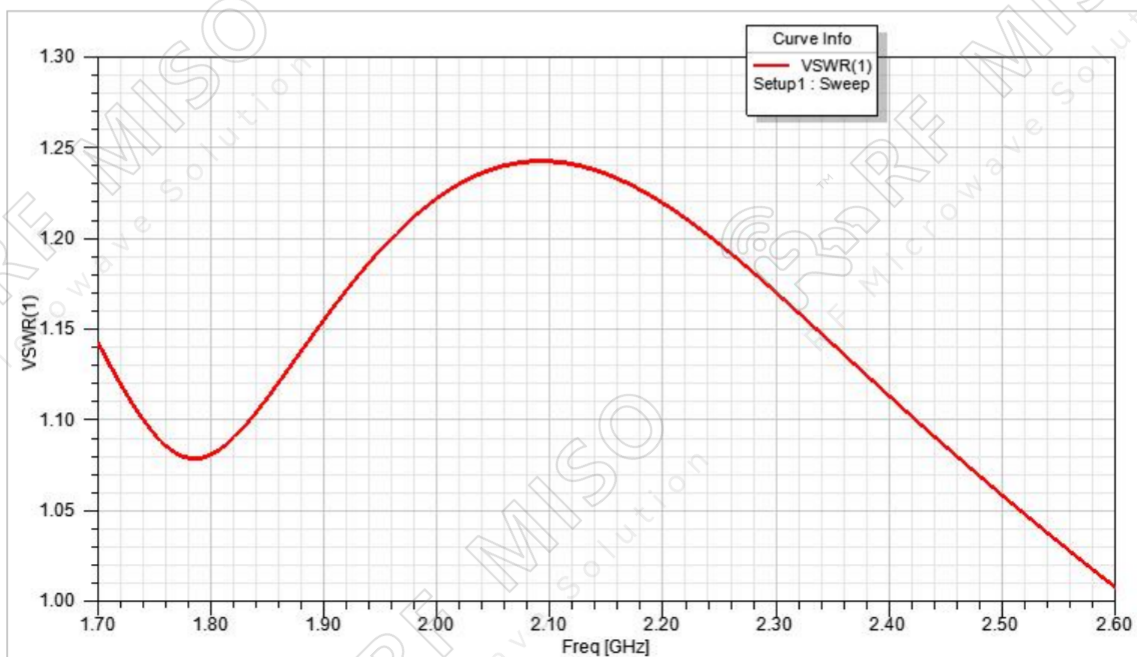

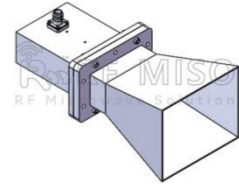

Standard Gain Horn Antenna
10dBi Typ. Gain, 1.70-2.60 GHz Frequency Range

Standard Gain Horn Antenna Data Sheet

RM-SGHA430-10

Gain

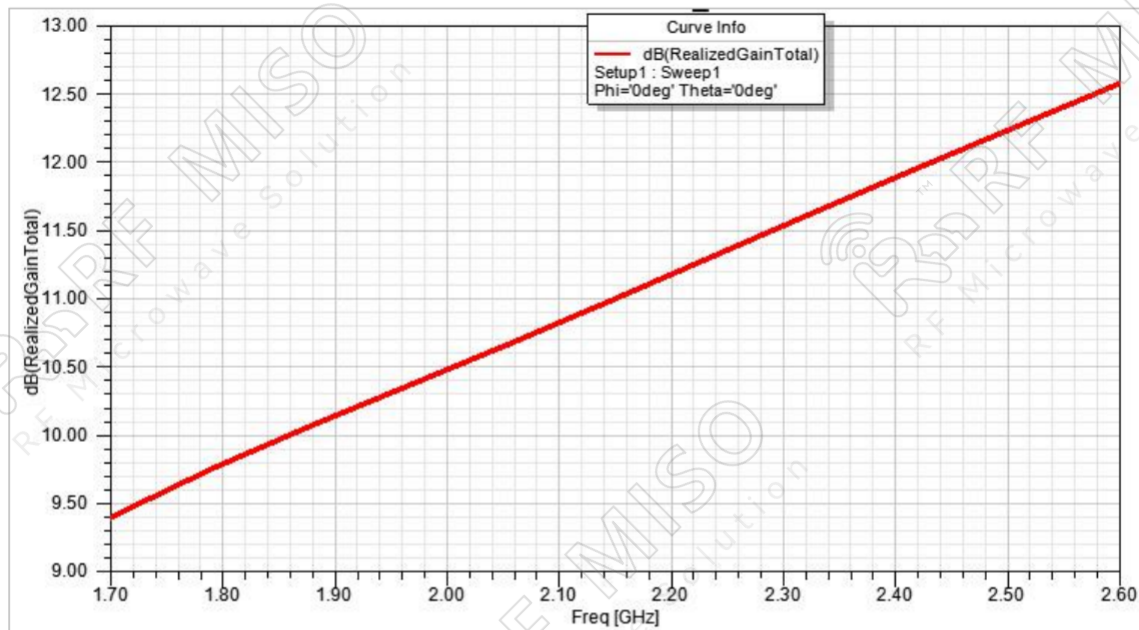

Gain Pattern E-plane

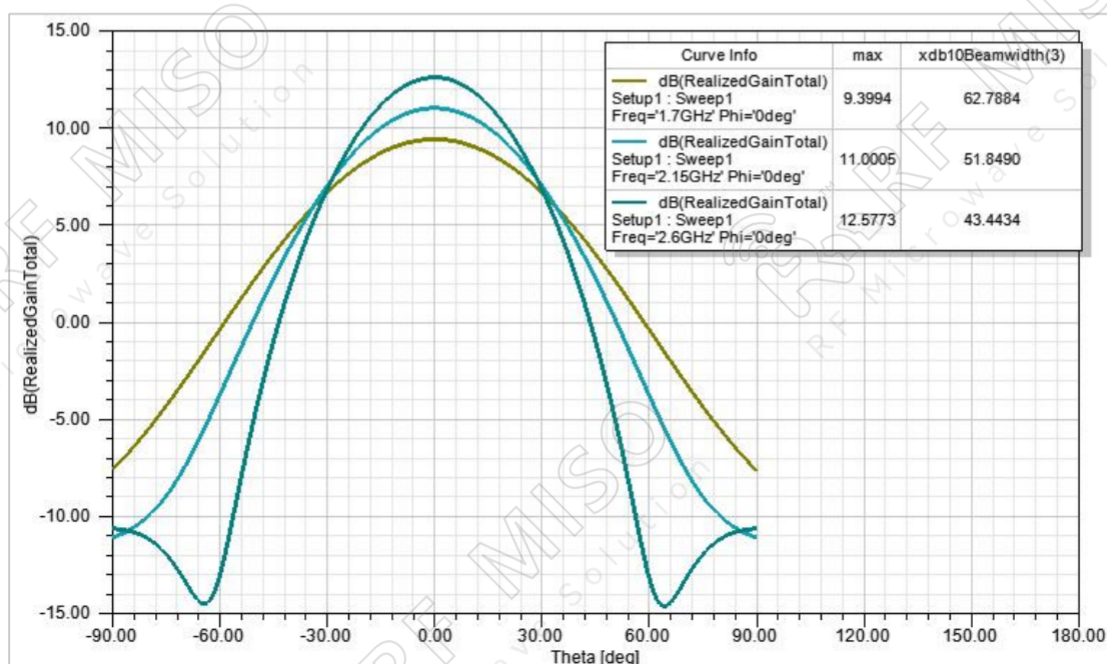

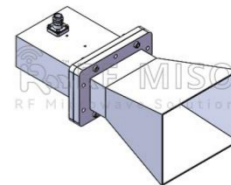

Standard Gain Horn Antenna
10dBi Typ. Gain, 1.70-2.60 GHz Frequency Range

Standard Gain Horn Antenna Data Sheet

RM-SGHA430-10

Gain Pattern H-plane

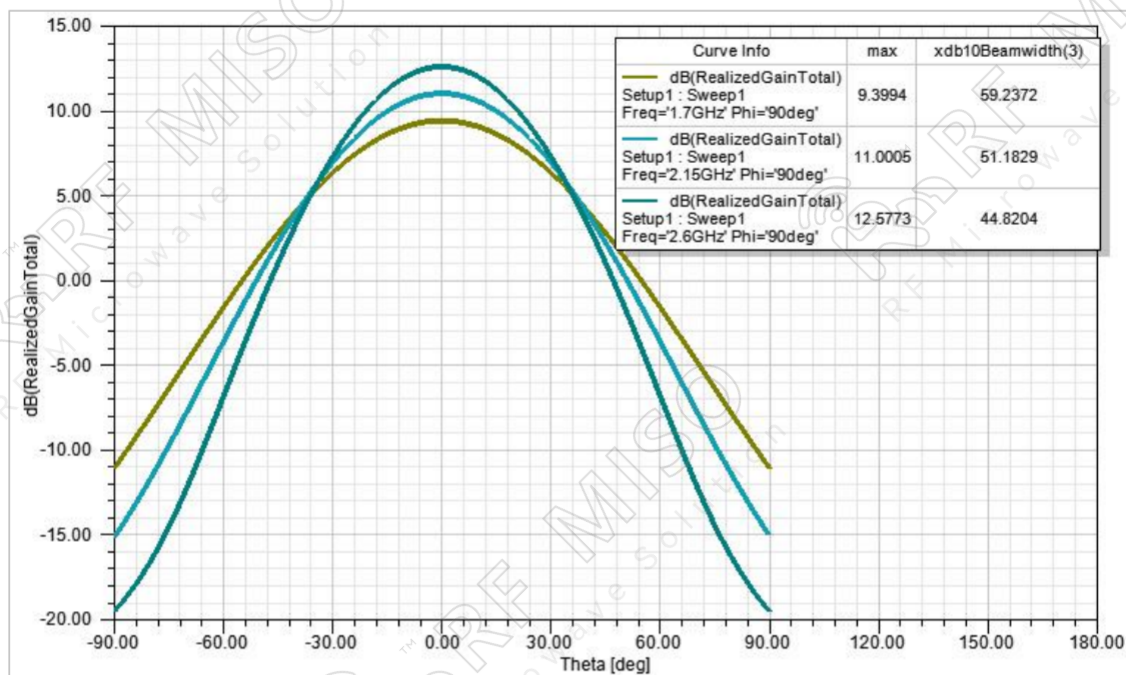

① **Rotating L-type bracket:** The rotating bracket is used for antenna polarization adjustment, and the tooling integrated with the bracket can precisely adjust the polarization directions of 0° , 45° , and 90° to ensure the accuracy and consistency of the calibration results.

Note:

- If the data presented is simulated. Actual data may vary unit to unit, slightly.
- Any foreign objects in the wave-guide will cause performance degradation and possible device damage.
- We can customize antennas according to your specific needs.