

Standard Gain Horn Antenna
10dBi Typ. Gain, 14.5-22 GHz Frequency Range

Standard Gain Horn Antenna Data Sheet

RM-SGHA51-10

Features

- Wave-guide and Connector Interface
- Low Side-lobe
- Linear Polarization
- High Return Loss

Descriptions

RF MISO's **Model RM-SGHA51-10** is a linear polarized standard gain horn antenna that operates from 14.5 to 22 GHz. The antenna offers a typical gain of 10 dBi and low VSWR 1.3:1. The antenna has a typical 3dB beamwidth of 51.6 degrees on the E plane and 52.1 degrees on H plane. This antenna has flange input and coaxial input for customers to rotate. Antenna mounting brackets include ordinary L-type mounting bracket and rotating L-type bracket①

Specifications

Parameters	Specification		Unit
Frequency Range	14.5-22		GHz
Wave-guide	WR42		
Gain	10 Typ.		dBi
VSWR	1.3 Typ.		
Polarization	Linear		
3 dB Beamwidth, E-Plane	51.6° Typ.		
3 dB Beamwidth, H-Plane	52.1° Typ.		
Interface	FBP180(F Type)	SMA-Female(C Type)	
Material	Al		
Finishing	Paint		
C Type Size (L*W*H)	55.6*30.2*32.6 (±5)		mm
Weight	0.018(F Type)	0.044(C Type)	kg
C Type Average Power	50		W
C Type Peak Power	3000		W
Operating Temperature	-40° ~+85°		° C

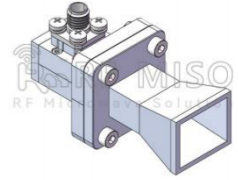

Standard Gain Horn Antenna
10dBi Typ. Gain, 14.5-22 GHz Frequency Range

Standard Gain Horn Antenna Data Sheet

RM-SGHA51-10

F-Type Mechanical Drawing (P/N: RM-SGHA51-10F)

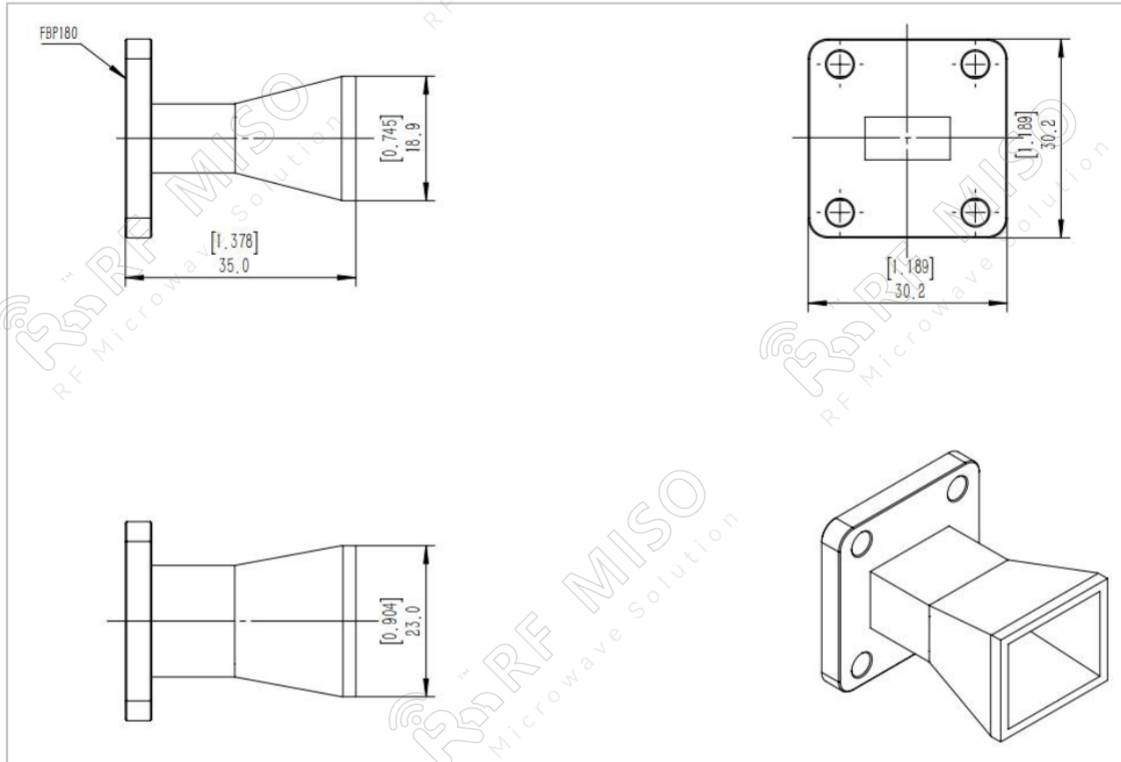

C-Type Mechanical Drawing (P/N: RM-SGHA51-10C)

N-type connector is available, please contact RF Miso.

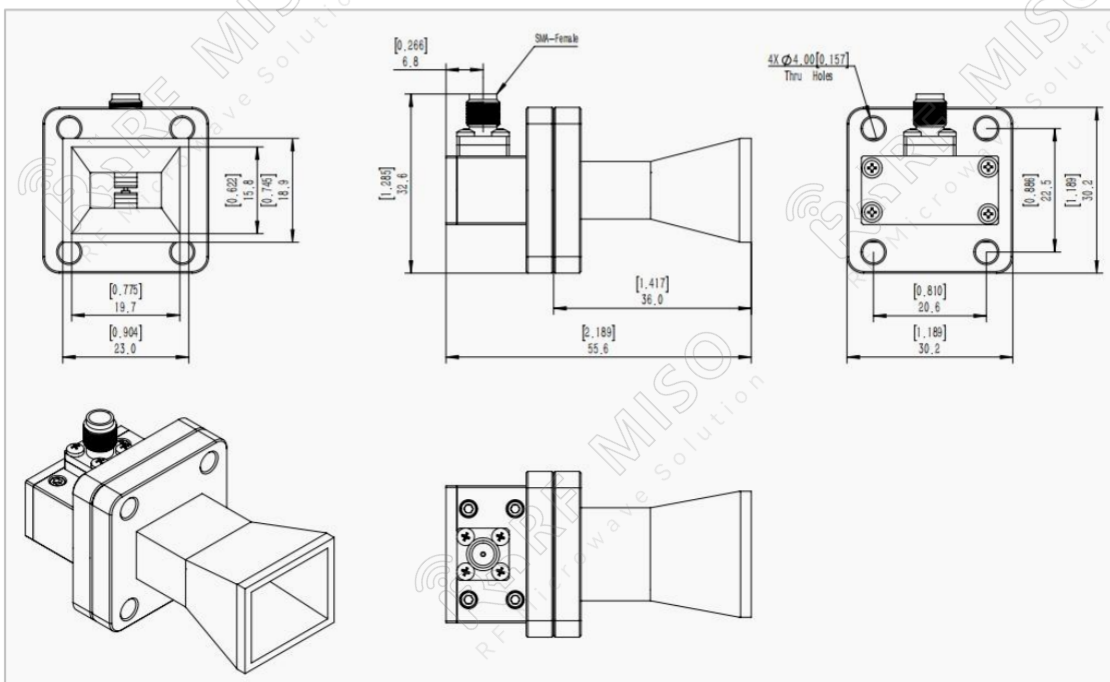

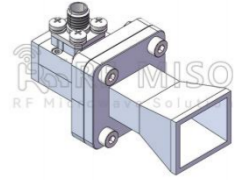

Standard Gain Horn Antenna
10dBi Typ. Gain, 14.5-22 GHz Frequency Range

Standard Gain Horn Antenna Data Sheet

RM-SGHA51-10

Mechanical Drawing with Ordinary L-type Mounting Bracket (P/N: RM-SGHA51-10CL)

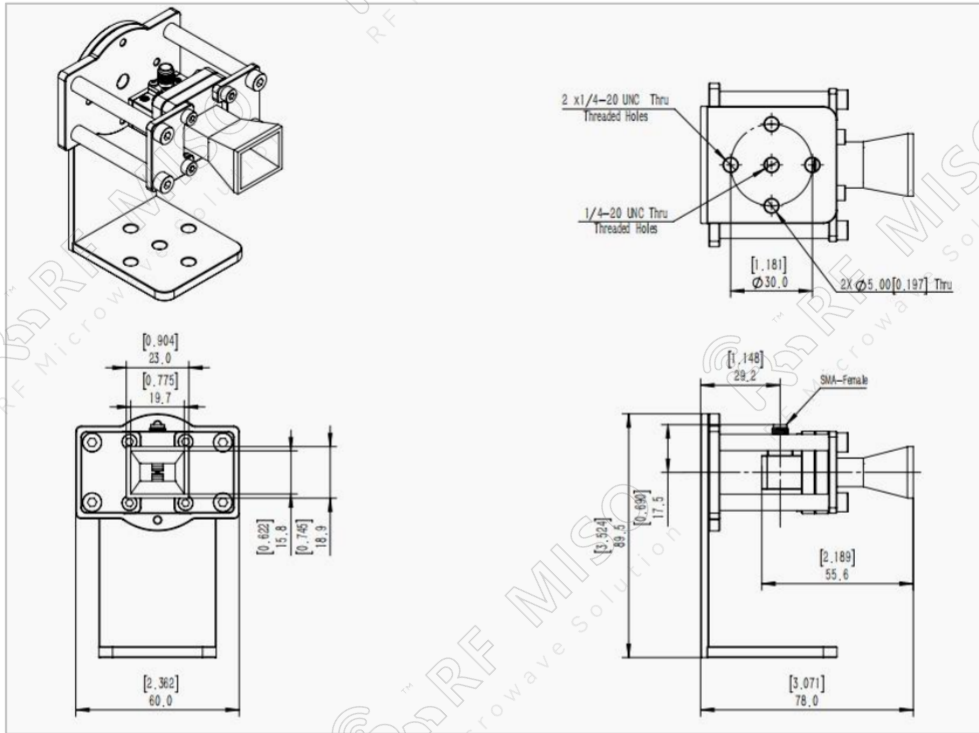

Mechanical Drawing with Rotating L-type Mounting Bracket (P/N: RM-SGHA51-10CR)

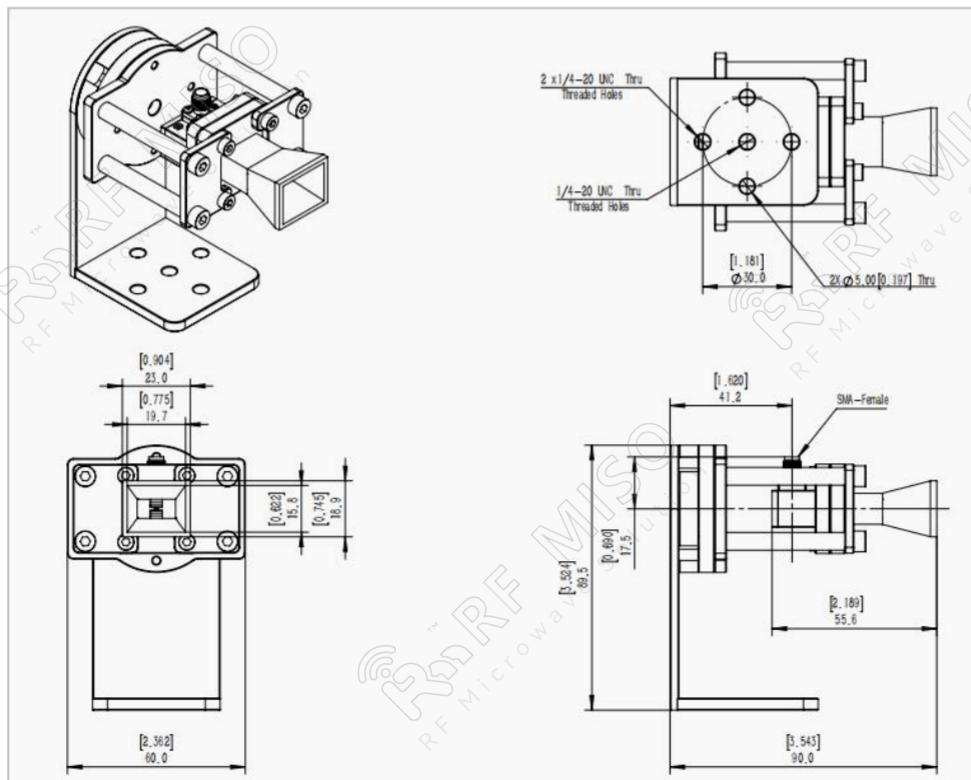

Standard Gain Horn Antenna
10dBi Typ. Gain, 14.5-22 GHz Frequency Range

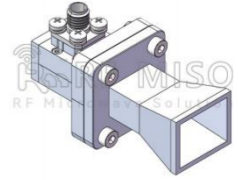

Standard Gain Horn Antenna Data Sheet

RM-SGHA51-10

Mechanical Drawing with Ordinary I-type Mounting Bracket (P/N: RM-SGHA51-10CI)

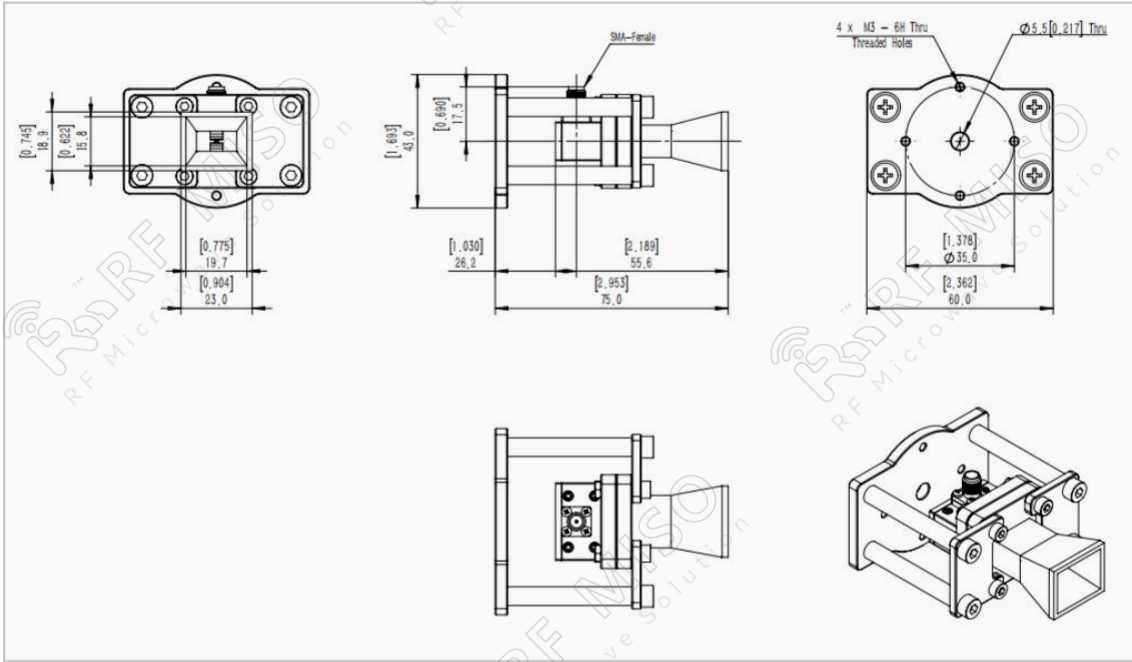

VSWR

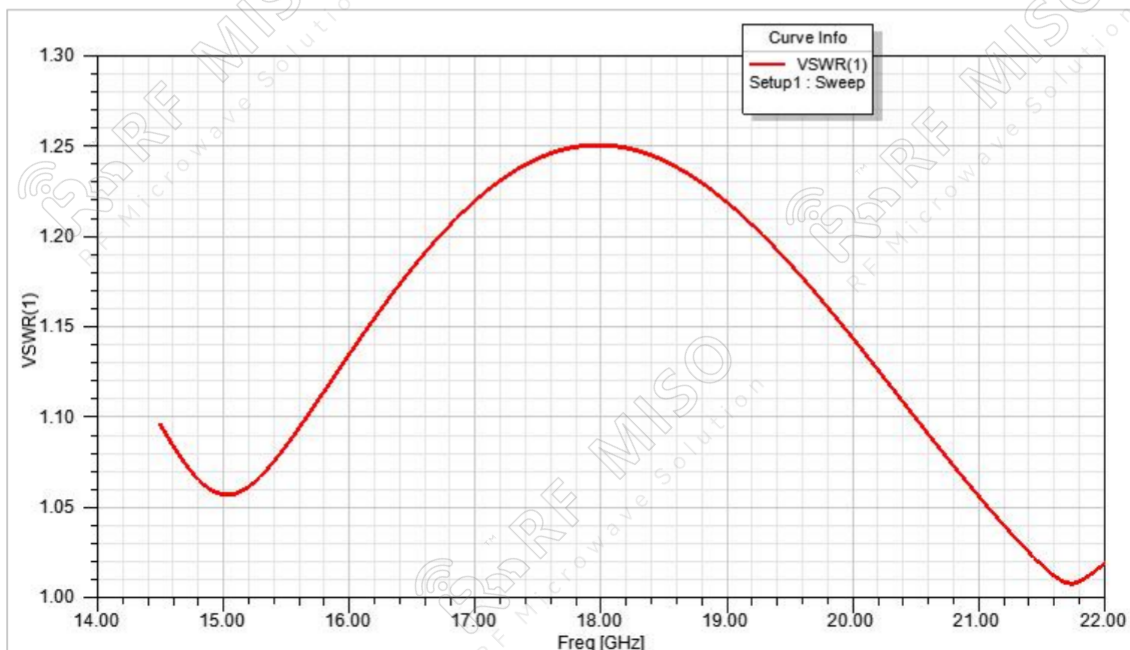

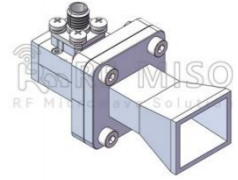

Standard Gain Horn Antenna
10dBi Typ. Gain, 14.5-22 GHz Frequency Range

Standard Gain Horn Antenna Data Sheet

RM-SGHA51-10

Gain

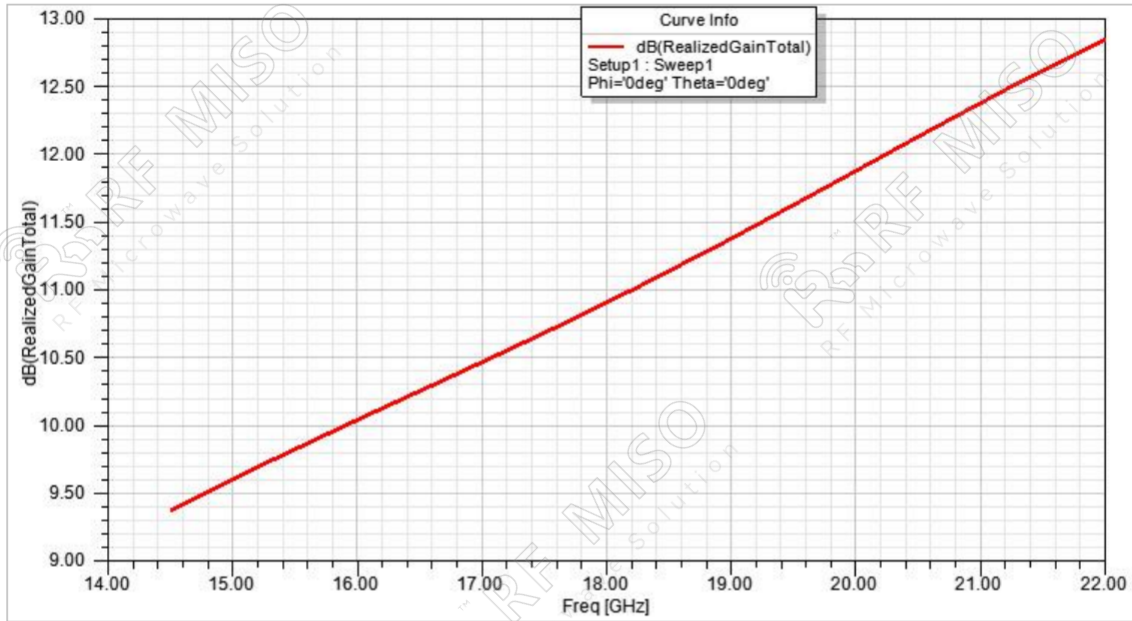

Gain Pattern E-plane

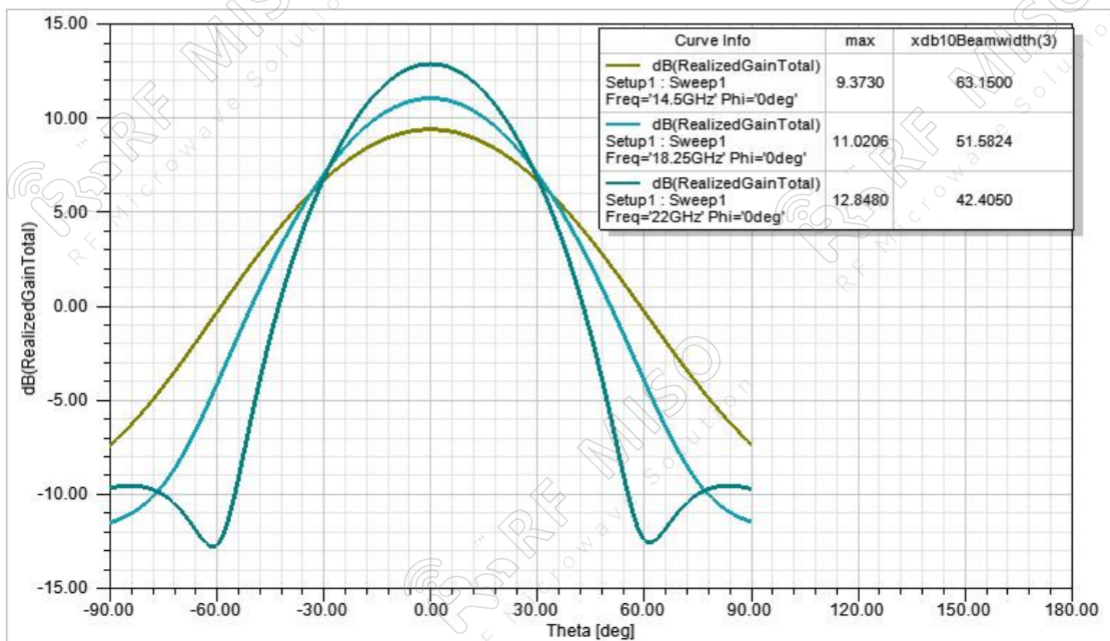

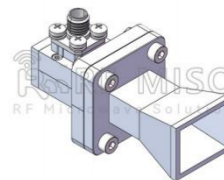

Standard Gain Horn Antenna
10dBi Typ. Gain, 14.5-22 GHz Frequency Range

Standard Gain Horn Antenna Data Sheet

RM-SGHA51-10

Gain Pattern H-plane

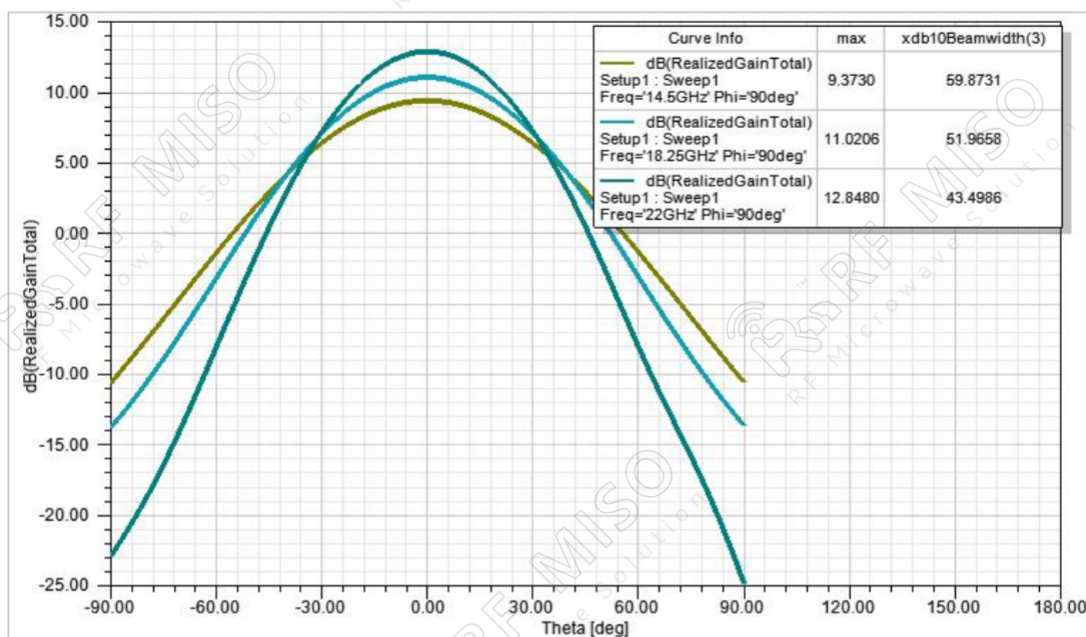

① **Rotating L-type bracket:** The rotating bracket is used for antenna polarization adjustment, and the tooling integrated with the bracket can precisely adjust the polarization directions of 0° , 45° , and 90° to ensure the accuracy and consistency of the calibration results.

Note:

- If the data presented is simulated. Actual data may vary unit to unit, slightly.
- Any foreign objects in the wave-guide will cause performance degradation and possible device damage.
- We can customize antennas according to your specific needs.