

Standard Gain Horn Antenna  
 10dBi Typ. Gain, 11.9-18 GHz Frequency Range

## Standard Gain Horn Antenna Data Sheet

**RM-SGHA62-10**

### Features

- Wave-guide and Connector Interface
- Low Side-lobe
- Linear Polarization
- High Return Loss

### Descriptions

RF MISO's **Model RM-SGHA62-10** is a linear polarized standard gain horn antenna that operates from 11.9 to 18 GHz. The antenna offers a typical gain of 10 dBi and low VSWR 1.3:1. The antenna has a typical 3dB beamwidth of 51.6 degrees on the E plane and 52.1 degrees on H plane. This antenna has flange input and coaxial input for customers to rotate. Antenna mounting brackets include ordinary L-type mounting bracket and rotating L-type bracket<sup>①</sup>

### Specifications

Parameters	Specification		Unit
Frequency Range	11.9-18		GHz
Wave-guide	WR62		
Gain	10 Typ.		dBi
VSWR	1.3 Typ.		
Polarization	Linear		
3 dB Beamwidth, E-Plane	51.6° Typ.		
3 dB Beamwidth, H-Plane	52.1° Typ.		
Interface	FBP140(F Type)	SMA-KFD(C Type)	
Material	Al		
Finishing	Paint		
C Type Size (L*W*H)	61*33.3*36 (±5)		mm
Weight	0.024(F Type)	0.057(C Type)	kg
C Type Average Power	50		W
C Type Peak Power	3000		W
Operating Temperature	-40° ~+85°		° C

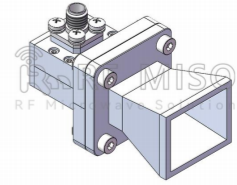

Standard Gain Horn Antenna  
10dBi Typ. Gain, 11.9-18 GHz Frequency Range

**Standard Gain Horn Antenna Data Sheet**

**RM-SGHA62-10**

**F-Type Mechanical Drawing (P/N: RM-SGHA62-10F)**

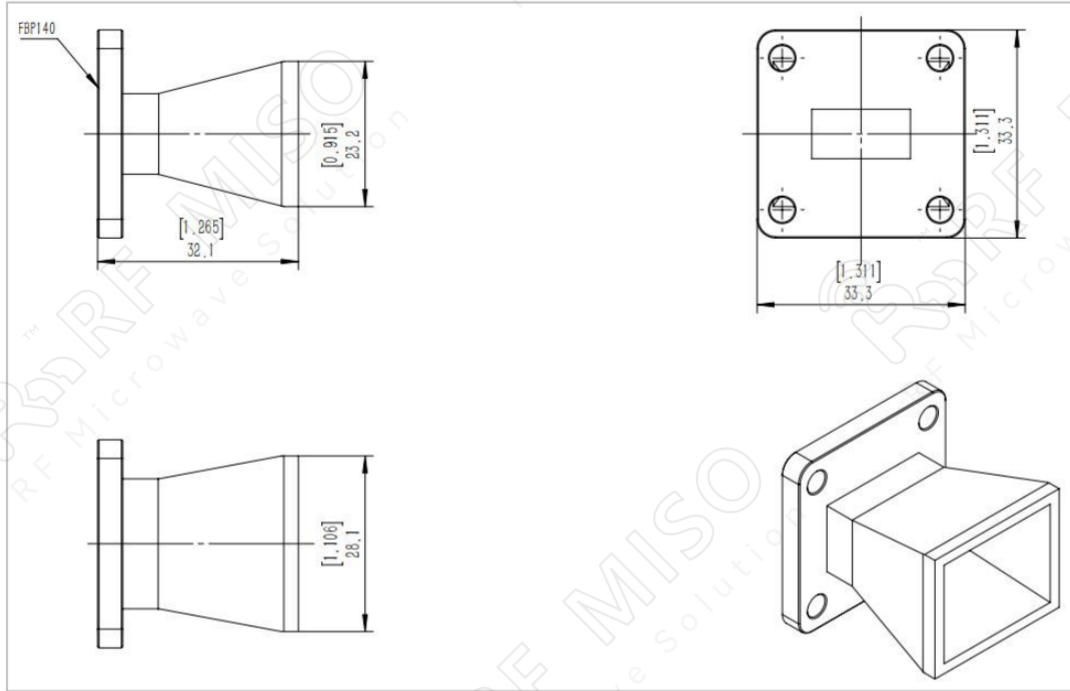

**C-Type Mechanical Drawing (P/N: RM-SGHA62-10C)**

N-type connector is available, please contact RF Miso.

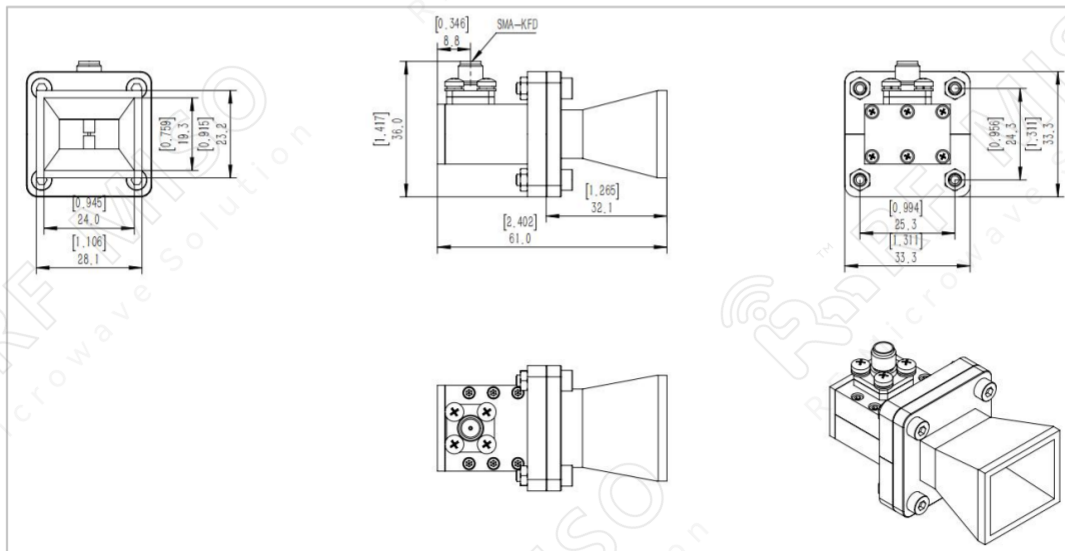

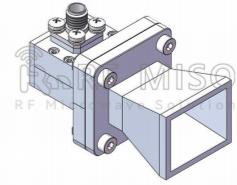

Standard Gain Horn Antenna  
10dBi Typ. Gain, 11.9-18 GHz Frequency Range

**Standard Gain Horn Antenna Data Sheet**

**RM-SGHA62-10**

**Mechanical Drawing with Ordinary L-type Mounting Bracket (P/N: RM-SGHA62-10CL)**

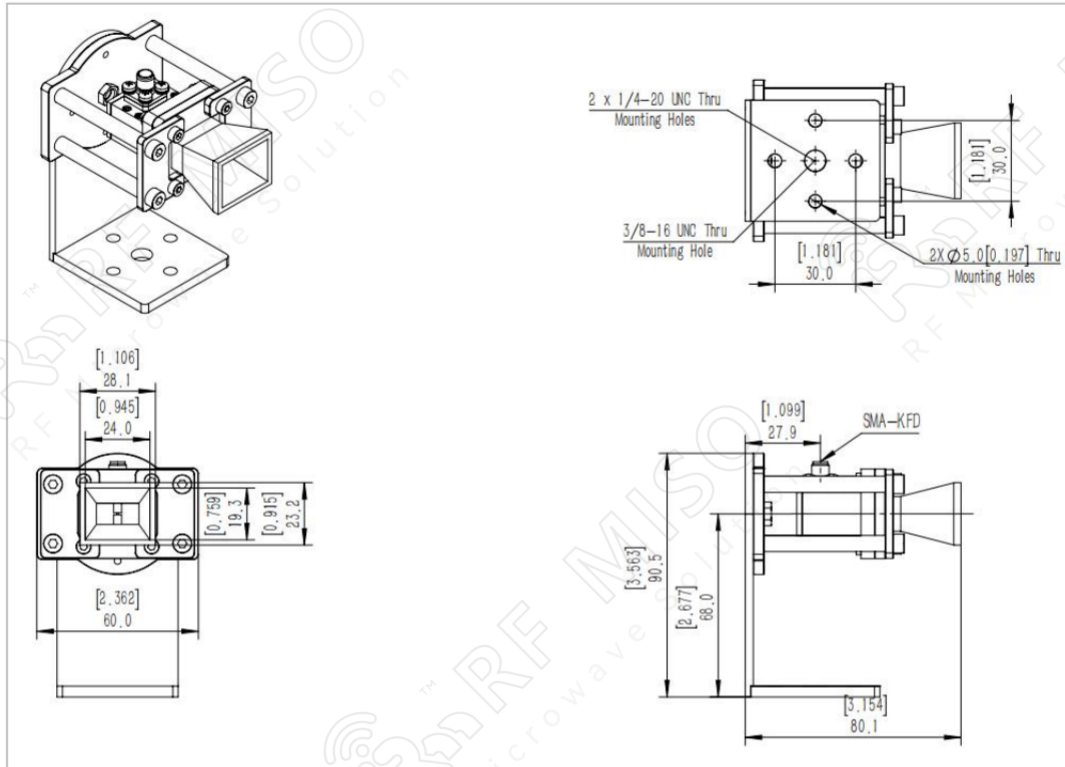

**Mechanical Drawing with Rotating L-type Mounting Bracket (P/N: RM-SGHA62-10CR)**

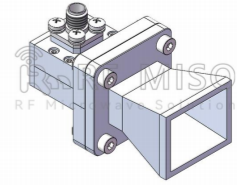

Standard Gain Horn Antenna  
10dBi Typ. Gain, 11.9-18 GHz Frequency Range

**Standard Gain Horn Antenna Data Sheet**

**RM-SGHA62-10**

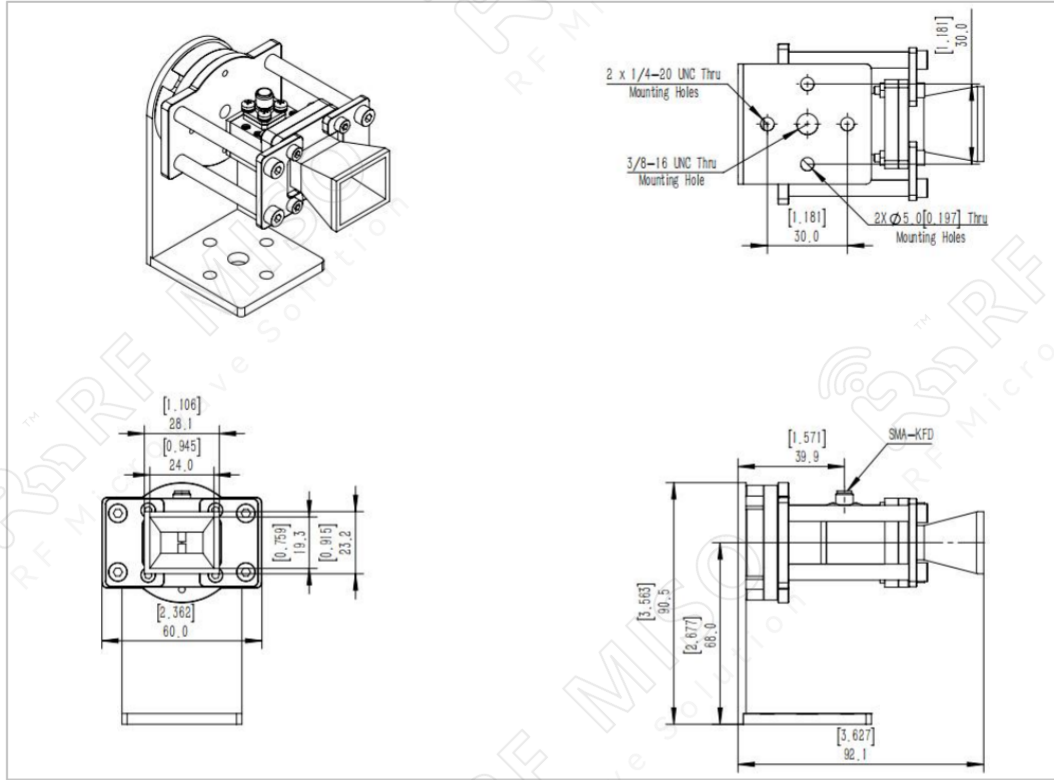

VSWR

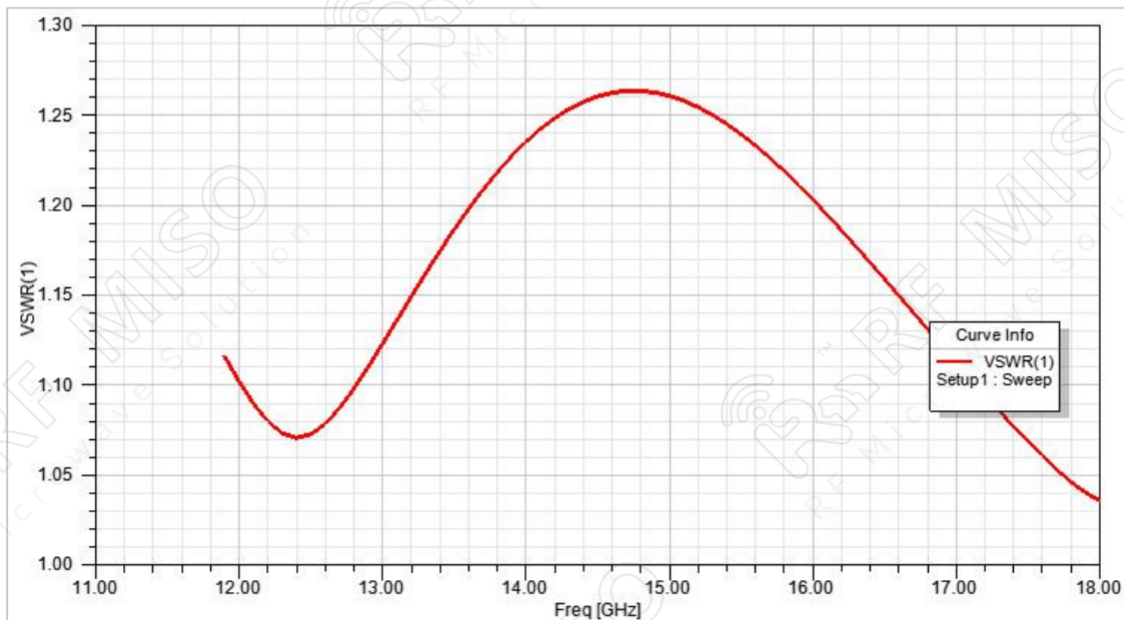

Gain

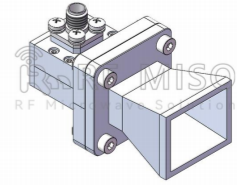

Standard Gain Horn Antenna  
10dBi Typ. Gain, 11.9-18 GHz Frequency Range

**Standard Gain Horn Antenna Data Sheet**

**RM-SGHA62-10**

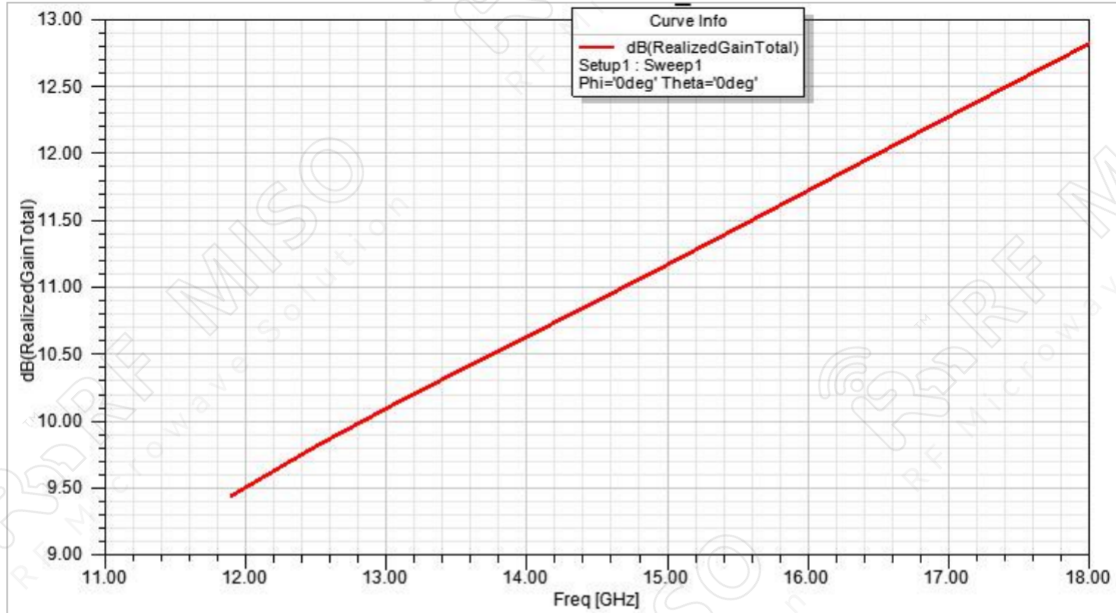

**Gain Pattern E-plane**

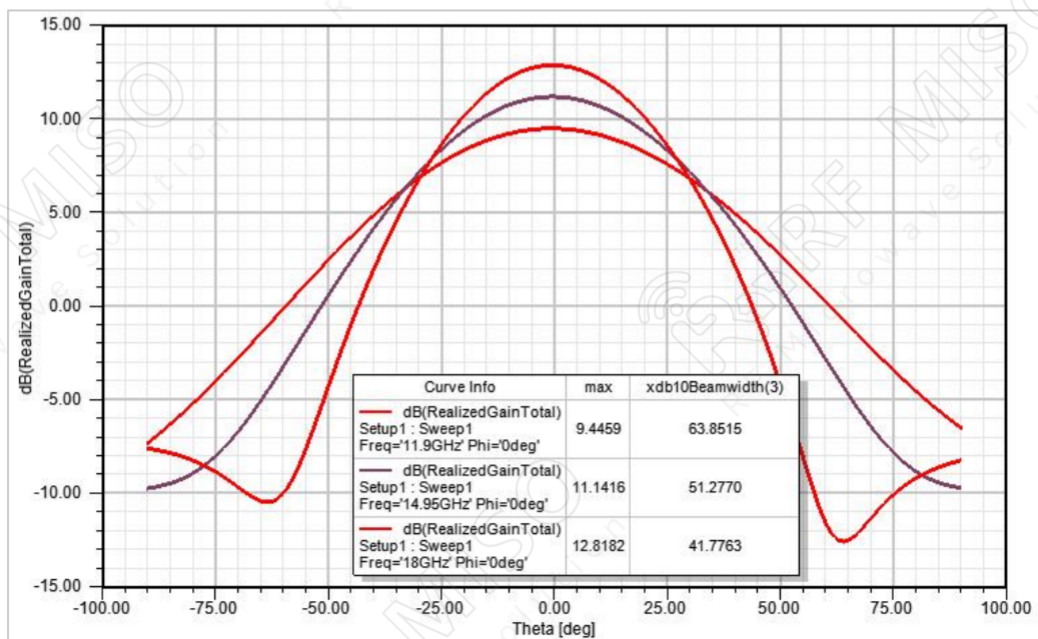

**Gain Pattern H-plane**

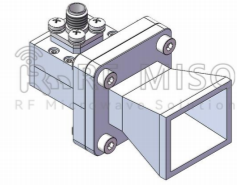

Standard Gain Horn Antenna  
10dBi Typ. Gain, 11.9-18 GHz Frequency Range

**Standard Gain Horn Antenna Data Sheet**

**RM-SGHA62-10**

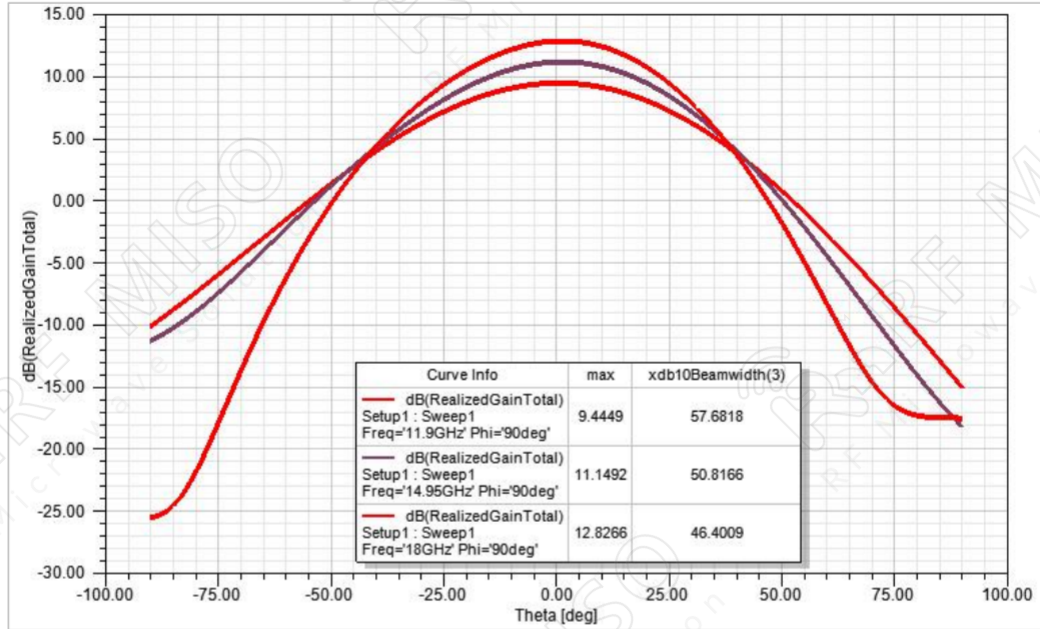

① **Rotating L-type bracket:** The rotating bracket is used for antenna polarization adjustment, and the tooling integrated with the bracket can precisely adjust the polarization directions of 0°, 45°, and 90° to ensure the accuracy and consistency of the calibration results.

Note:

- If the data presented is simulated. Actual data may vary unit to unit, slightly.
- Any foreign objects in the wave-guide will cause performance degradation and possible device damage.
- We can customize antennas according to your specific needs.