

Standard Gain Horn Antenna
20dBi Typ. Gain, 11.9-18 GHz Frequency Range

Standard Gain Horn Antenna Data Sheet

RM-SGHA62-20

Features

- Wave-guide and Connector Interface
- Low Side-lobe
- Linear Polarization
- High Return Loss

Descriptions

RF MISO's **Model RM-SGHA62-20** is a linear polarized standard gain horn antenna that operates from 11.9 to 18 GHz. The antenna offers a typical gain of 20 dBi and low VSWR 1.3:1. The antenna has a typical 3dB beamwidth of 17.3 degrees on the E plane and 17.5 degrees on H plane. This antenna has flange input and coaxial input for customers to rotate. Antenna mounting brackets include ordinary L-type, I-type mounting bracket and rotating L-type bracket^①

Specifications

Parameters	Specification		Unit
Frequency Range	11.9-18		GHz
Wave-guide	WR62		
Gain	20 Typ.		dBi
VSWR	1.3 Typ.		
Polarization	Linear		
3 dB Beamwidth, E-Plane	17.3° Typ.		
3 dB Beamwidth, H-Plane	17.5° Typ.		
Interface	FBP140(F Type)	SMA-F(C Type)	
Material	Al		
Finishing	Paint		
C Type Size (L*W*H)	185.1*81.3*61.4 (±5)		mm
Weight	0.152(F Type)	0.182(C Type)	kg
C Type Average Power	50		W
C Type Peak Power	3000		W
Operating Temperature	-40° ~+85°		° C

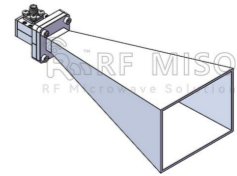

Standard Gain Horn Antenna
20dBi Typ. Gain, 11.9-18 GHz Frequency Range

Standard Gain Horn Antenna Data Sheet

RM-SGHA62-20

F-Type Mechanical Drawing (P/N: RM-SGHA62-20F)

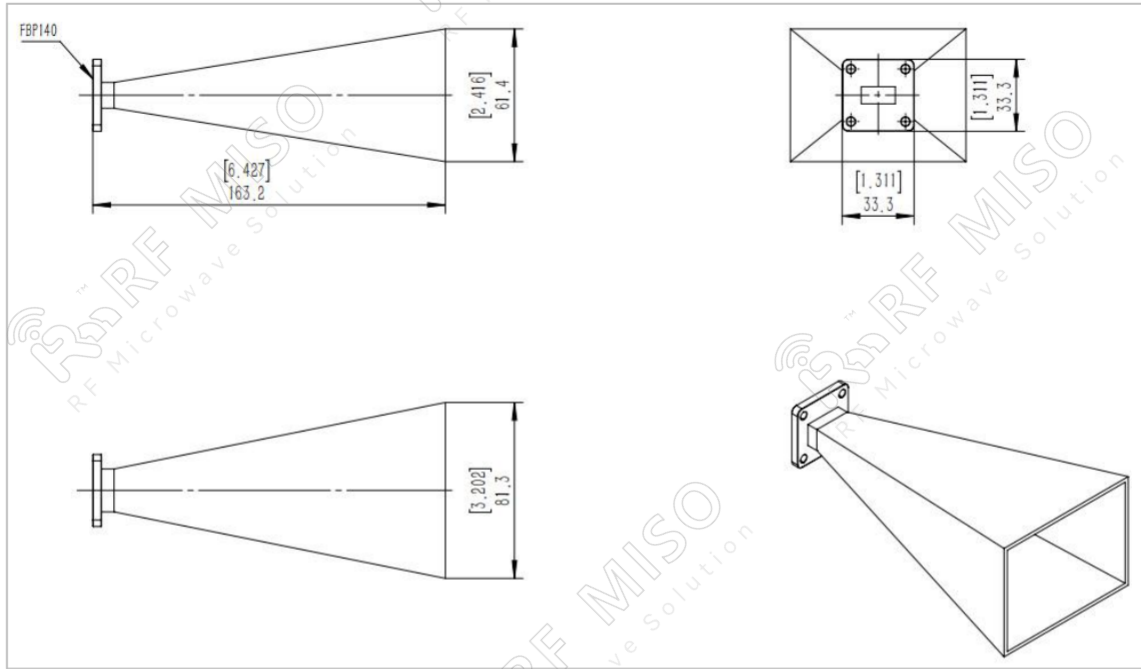

C-Type Mechanical Drawing (P/N: RM-SGHA62-20C)

N-type connector is available, please contact RF Miso.

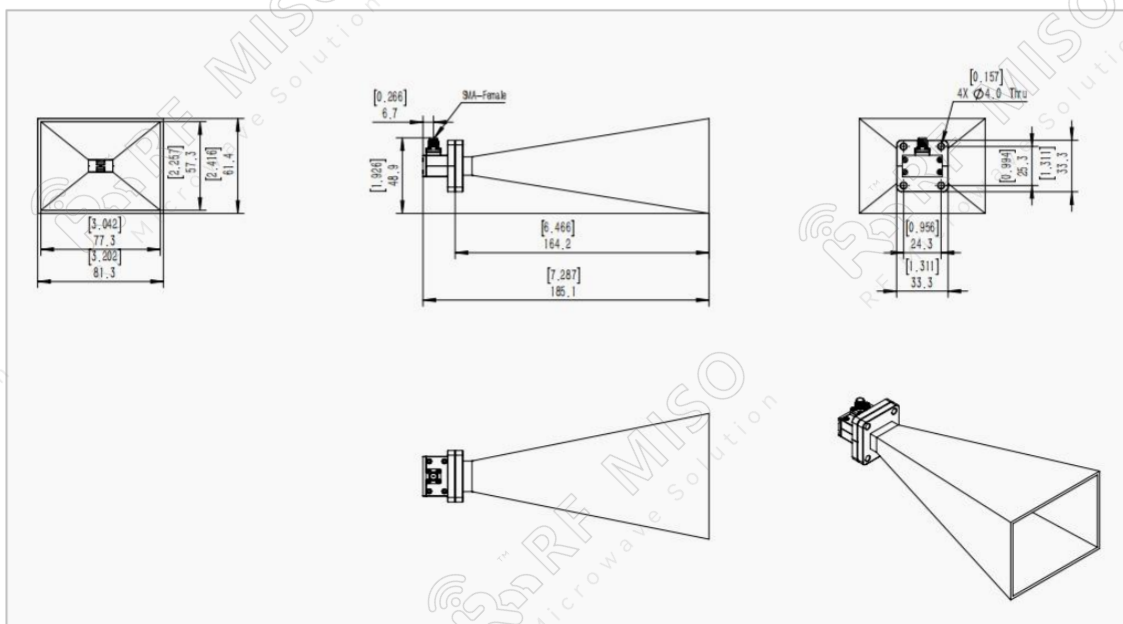

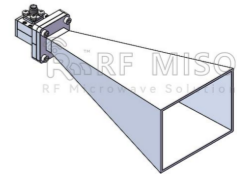

Standard Gain Horn Antenna
20dBi Typ. Gain, 11.9-18 GHz Frequency Range

Standard Gain Horn Antenna Data Sheet

RM-SGHA62-20

Mechanical Drawing with Ordinary L-type Mounting Bracket (P/N: RM-SGHA62-20CL)

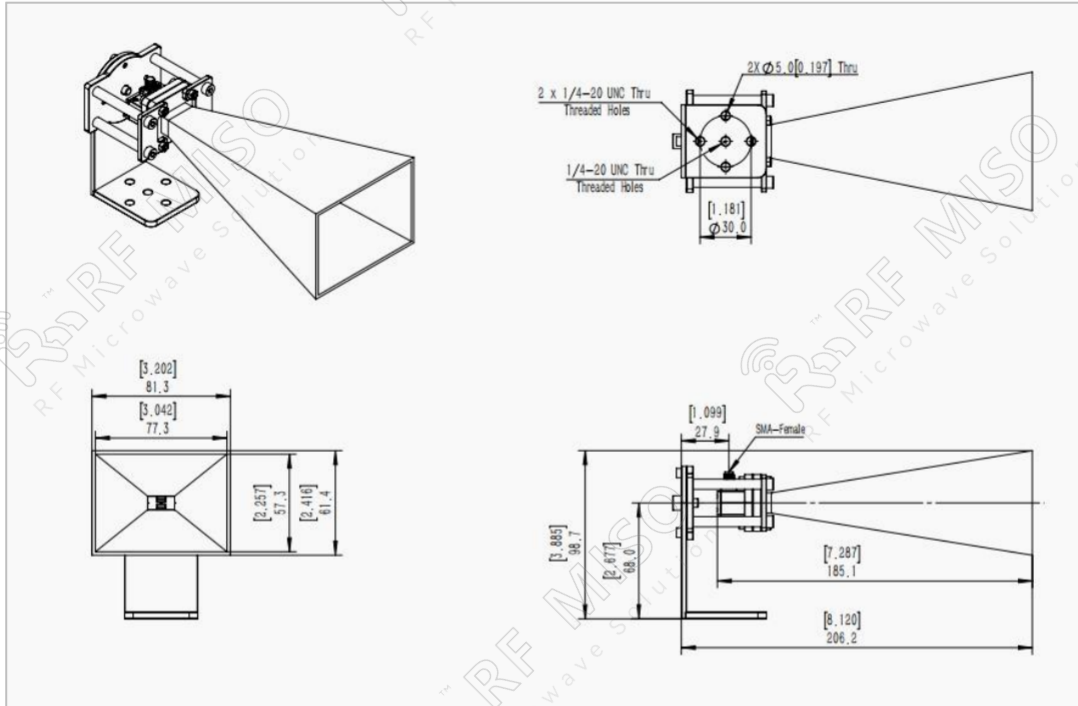

Mechanical Drawing with Rotating L-type Mounting Bracket (P/N: RM-SGHA62-20CR)

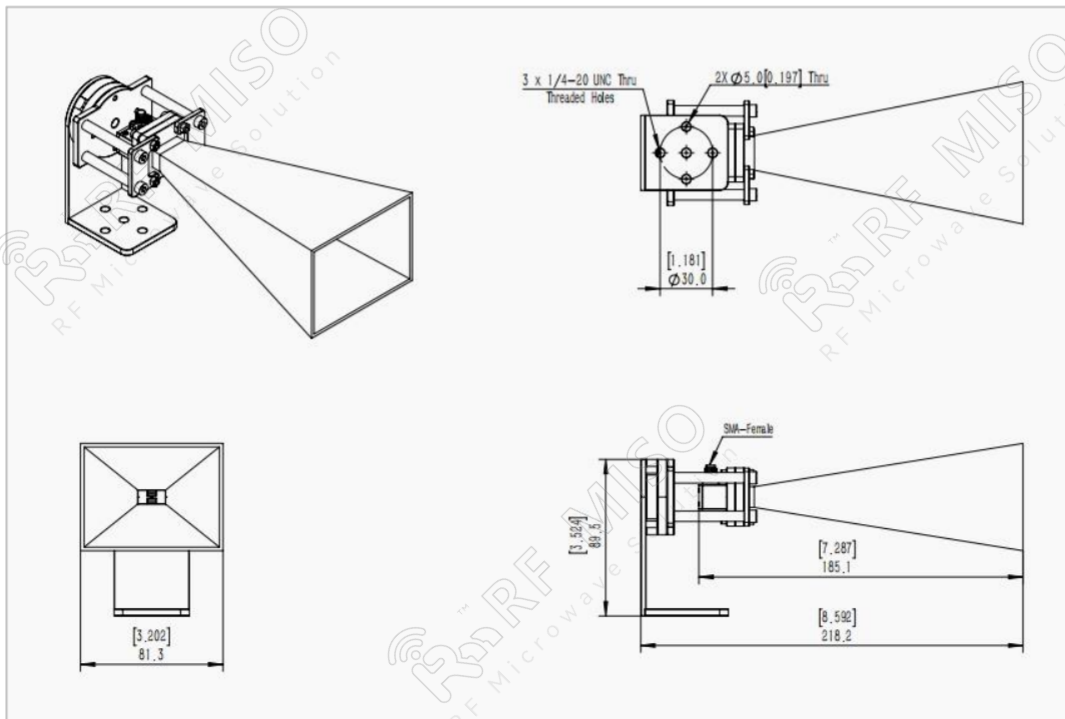

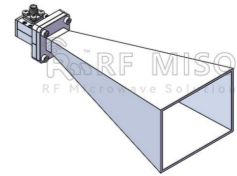

Standard Gain Horn Antenna
20dBi Typ. Gain, 11.9-18 GHz Frequency Range

Standard Gain Horn Antenna Data Sheet

RM-SGHA62-20

Mechanical Drawing with Ordinary I-type Mounting Bracket (P/N: RM-SGHA62-20CI)

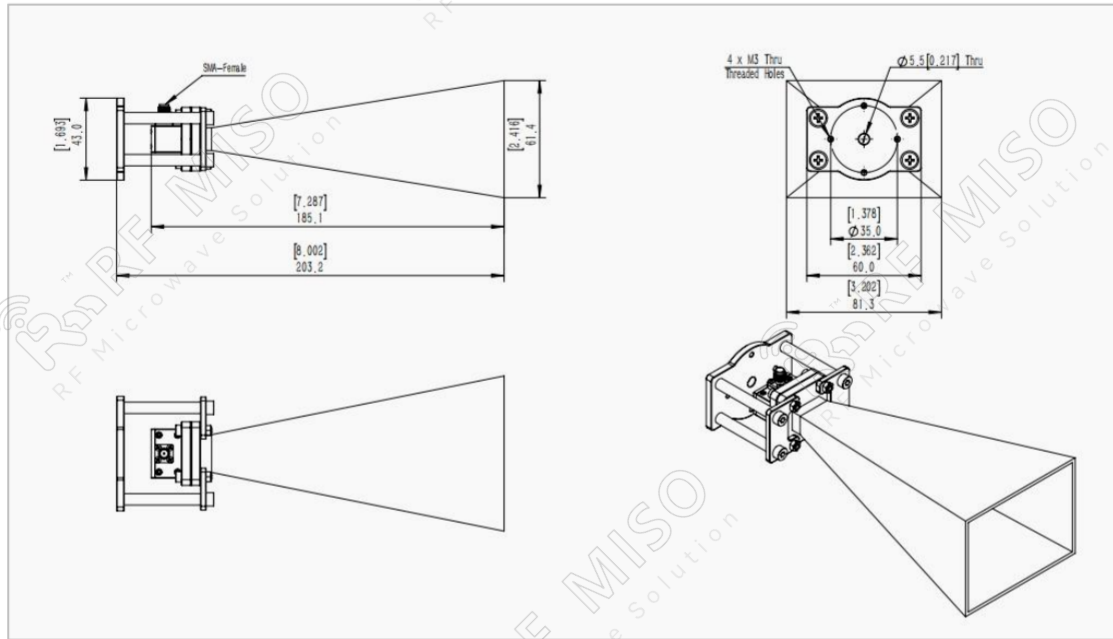

Simulation Data

VSWR



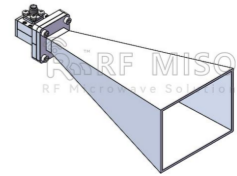

Standard Gain Horn Antenna
20dBi Typ. Gain, 11.9-18 GHz Frequency Range

Standard Gain Horn Antenna Data Sheet

RM-SGHA62-20

Gain

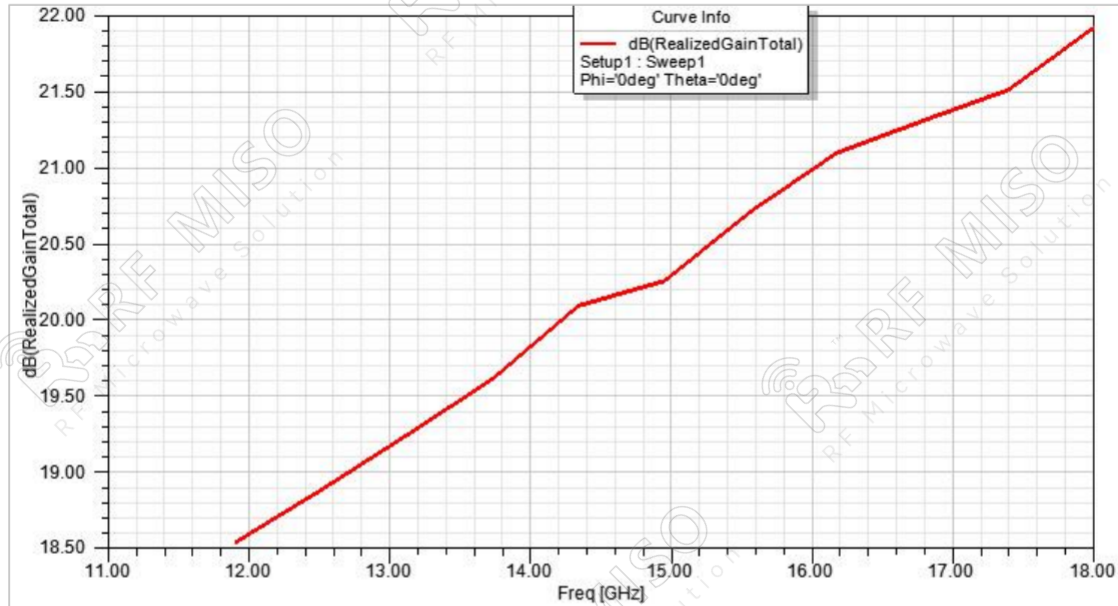

Gain Pattern E-plane

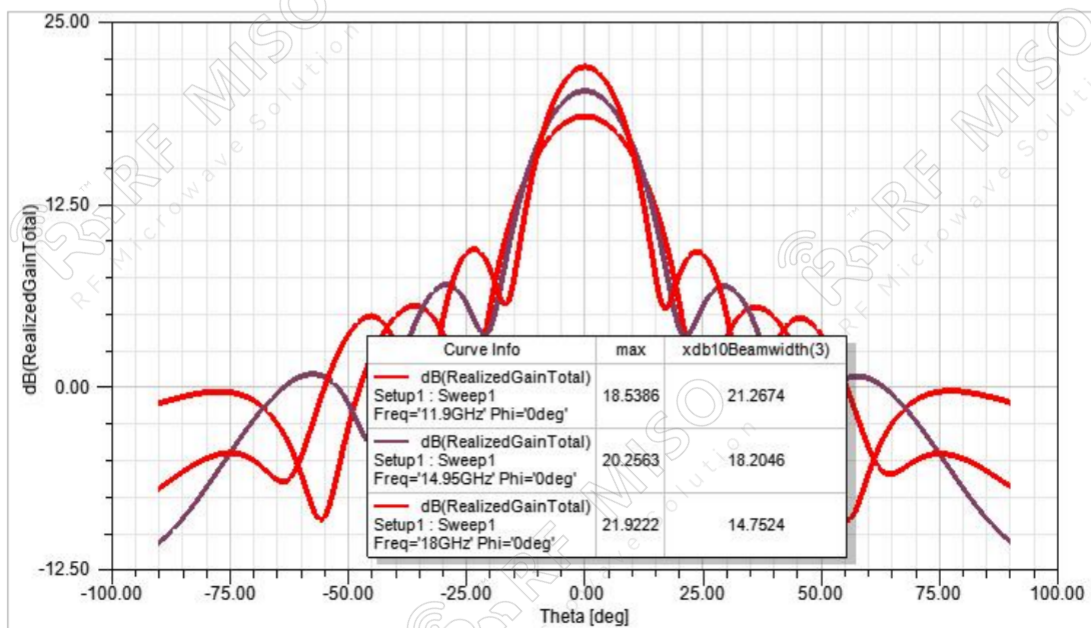

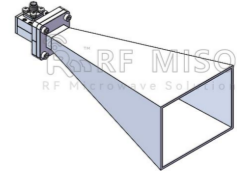

Standard Gain Horn Antenna
20dBi Typ. Gain, 11.9-18 GHz Frequency Range

Standard Gain Horn Antenna Data Sheet

RM-SGHA62-20

Gain Pattern H-plane

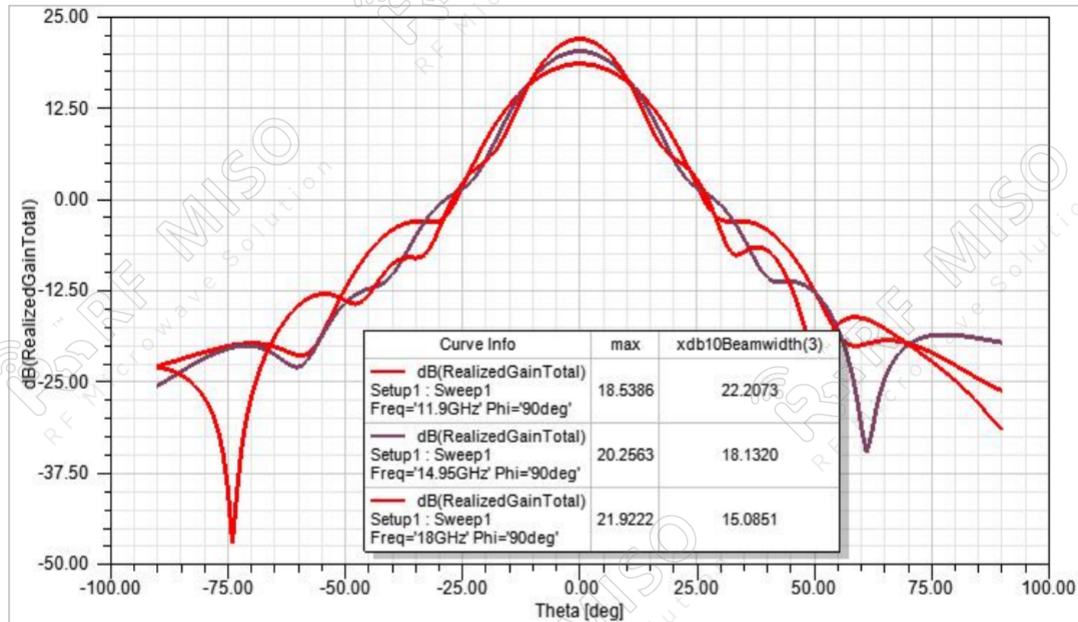

① **Rotating L-type bracket:** The rotating bracket is used for antenna polarization adjustment, and the tooling integrated with the bracket can precisely adjust the polarization directions of 0° , 45° , and 90° to ensure the accuracy and consistency of the calibration results.

Note:

- If the data presented is simulated. Actual data may vary unit to unit, slightly.
- Any foreign objects in the wave-guide will cause performance degradation and possible device damage.
- We can customize antennas according to your specific needs.