



Waveguide Probe Antenna Data Sheet

RM-WPA650-7

Features

- WR-650 Rectangular Waveguide Interface
- Linear Polarization
- High Return Loss
- Precisely Machined

Description

The **RM-WPA650-7** is a probe antenna that operates from 1.12GHz to 1.75GHz. The antenna offers 7 dBi typical gain. The antenna supports linear polarized waveforms. The input of this antenna is a WR-650 waveguide with a FDP14 flange.

Specifications

RM-WPA650-7			
Item	Specification		Units
Frequency Range	1.12-1.75		GHz
Gain	7 Typ.		dBi
VSWR	≤2		
Polarization	Linear		
Cross-polarization Isolation	50 Typ.		dB
Waveguide Size	WR-650		
Interface	FDP14 (F Type)	SMA-F(C Type)	
C Type Size(L*W*H)	536*300*300(±5)		mm
Weight	1.991(F Type)	6.214(C Type)	kg
Body Material	Al		
Surface Treatment	Paint		
C Type Power Handling, CW	50		w
C Type Power Handling, Peak	3000		w



Waveguide Probe Antenna Data Sheet

RM-WPA650-7

F-Type Mechanical Drawing (P/N: RM-WPA650-7F)

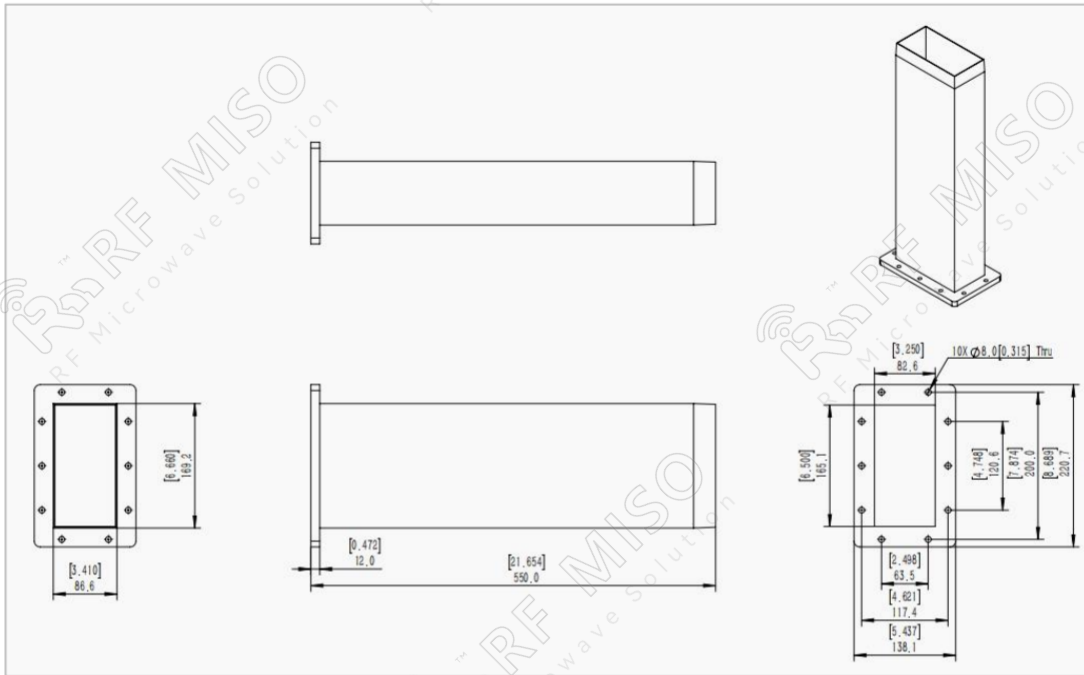

C-Type Mechanical Drawing (P/N: RM-WPA650-7C)

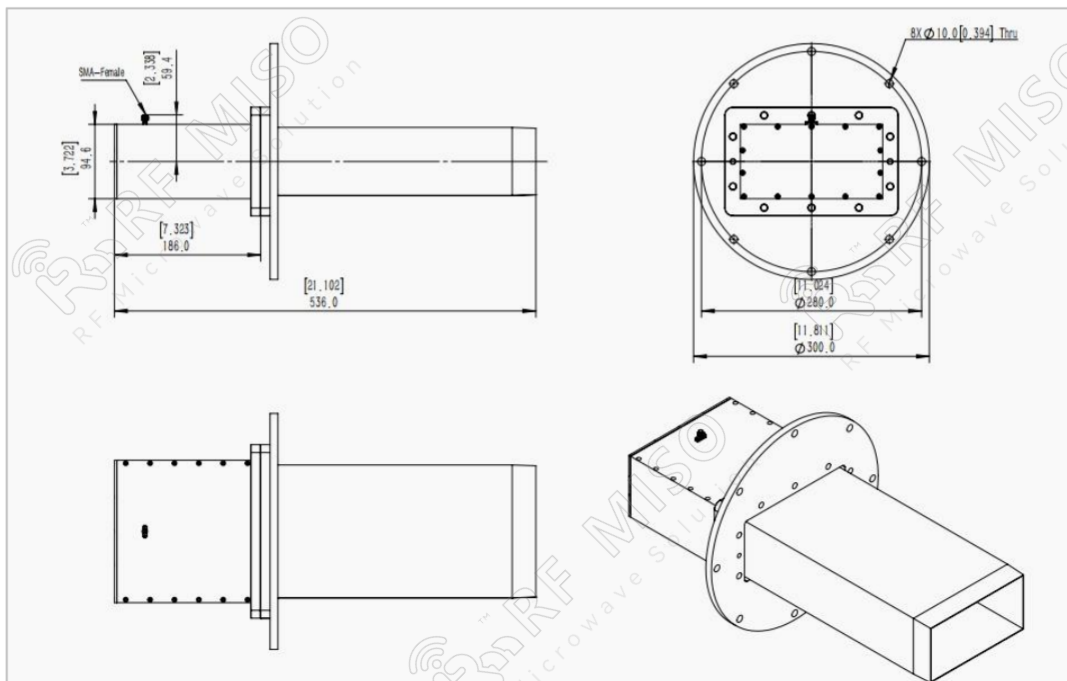



Waveguide Probe Antenna Data Sheet

RM-WPA650-7

Simulated Data

VSWR

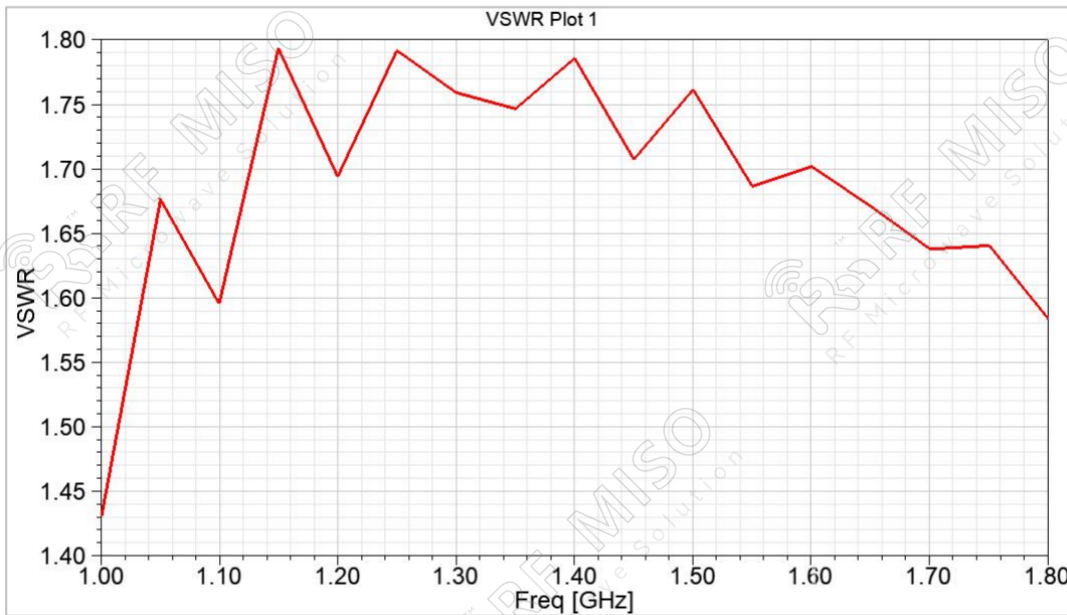

Polarization

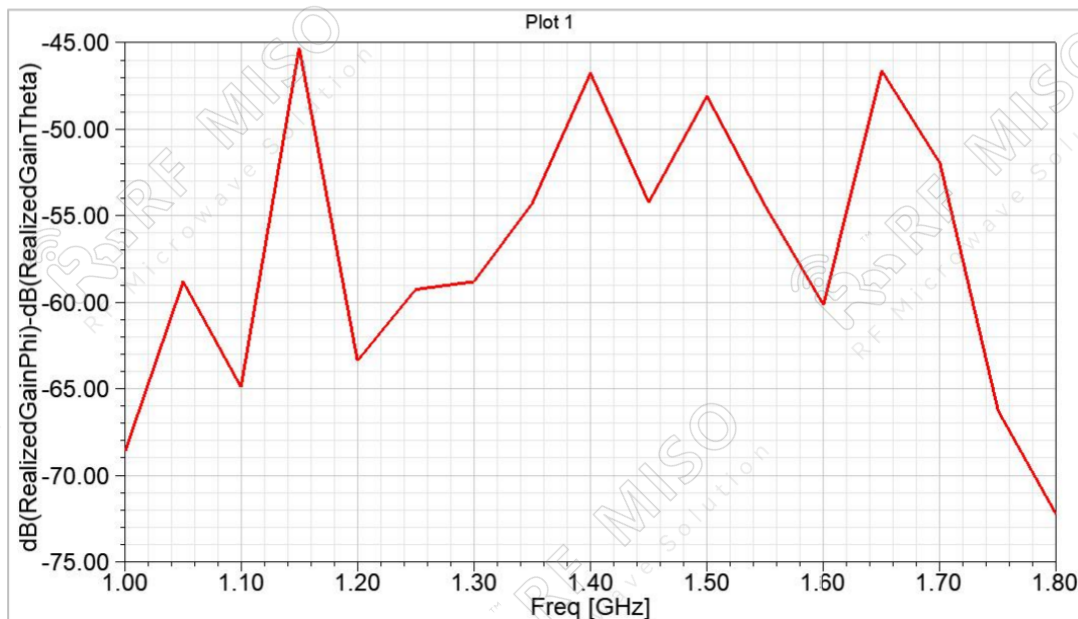



Waveguide Probe Antenna Data Sheet

RM-WPA650-7

Gain

